



# All-In-One Standalone Solar Power System

## USER MANUAL

### Raython series



## About TBB Renewable

### One-stop Power Solution Provider

Found in 2007 with location in Xiamen city, TBB Renewable is specialized in providing off-grid, mini-grid and ESS solutions. With 16 years experience, TBB Renewable has become a global solution provider in the renewable market serving clients across more than 50 countries, committed to providing one-stop power solution, including power generation, power conversion, storage, system monitoring & cloud, system accessories. Integrated all-in-one system is also available for easier and quicker installation.

### Increasing Installations and Comprehensive Service

Till now, more than 450,000 sets of TBB off grid system are operating stably all over the world, including commercial and residential applications. TBB Renewable also provides comprehensive service to its customers in order to achieve optimal satisfaction.

### Innovative Supplier in Inverter Industry, Quality First

As a national recognized high-tech enterprise, TBB Renewable designs and manufactures its products at its own industrial park, supported by a strong R&D team with 150+ staffs. Combing the multiple modern technologies, TBB Renewable aims to supply innovative and green digital controlled system for various applications. TBB Renewable has obtained ISO9001 quality management system and more than 100 patents and copyrights, to ensure that performance and quality go hand-in-hand across the entire range.

### International Green Energy Advocate

In collaboration with our partners and customers, we are helping people turn to a self-sufficient, decentralized and renewable energy supply.

## Disclaimer

Unless specially agreed in writing, **TBB Renewable (Xiamen) Co, Ltd**

- Take no warranty as to the accuracy, sufficiency of suitability of any technical or other information provided in this manual or other documentation.
- Assumes no responsibility or liability for loss or damage, whether direct, indirect, consequential or incidental, which might arise out of the use of such information
- TBB offer standard warranty with its products, taking no responsibility for direct or indirect loss due to equipment failure.

## About this Manual

This manual describes our product features and provides procedure of installations. This manual is for anyone intending to install our equipment.

## General Instruction

Thanks for choosing our products and this manual is suitable for RAYTHON series Solar Intelligent Energy Storage System.

This chapter contains important safety and operation instructions. Read and keep this User Guide well for later reference.

The RAYTHON series needs to be installed by professionals and please pay attention to the following points prior to installation:

- 1> Please check the DC input voltage or battery voltage is the same to the nominal input voltage of this inverter.
- 2> Please connect positive terminal “+” of the battery to “+” input of the inverter.
- 3> Please connect negative terminal “-” of the battery to “-” input of the inverter.
- 4> Please use the shortest cable to connect and ensure the secure connection.
- 5> While connecting, please secure the connection and avoid short cut between positive terminal and negative terminal of the battery, to avoid damage to the battery.
- 6> The system will have high voltage inside. Only authorized electrician can open the case.
- 7> The system WAS NOT designed to use in any life retaining equipment.



## Warning

- The system voltage is much higher than the safety value. Direct contact or indirect contact with wet objects could be dangerous.
- Substandard or incorrect operations might lead to accidents like fire or electric shock.
- The upstream protective switch must be disconnected before conducting electrical connection.
- Electrical connection must be finished before letting AC in.
- Make sure the cables have been connected to the right poles of battery pack before connecting the output cable or battery cable.
- The cabinet for parallel connection is a general product for outdoor use with built-in Level II surge protection device.
- This product should be kept away from liquid and must not be installed below positions prone to water leakage such as air conditioning ducts, ventilation outlets, or wiring windows, etc.
- Make sure there is not condensation inside the cabinets. When there is liquid inside, the power should be turned off immediately. Then, please turn to relevant staff for troubleshooting.
- When the temperature is too low, huge impact or vibration might result in brittle cracking of the plastic cable sheath. To ensure safety, cable installation should be proceeded in above 0°C.
- If the cables are stored under 0°C, they are supposed to be placed in indoor temperature for more than 24 hours before being installed.

# Content

1.0 General Safety Instruction .....	1
1.1 Safety Instruction .....	1
1.2 Symbols Used in the Documentation .....	1
1.3 General Precaution .....	1
1.4 Precaution Regarding Battery Operation .....	2
2.0 System Description .....	3
2.1 Equipment layout .....	4
2.2 Raython Cabinet Dimensions .....	7
2.3 Apollo Matrix Solar Hybrid Inverter .....	8
2.4 Kinergier Pro Inverter Charger .....	9
2.5 Solar Mate MPPT Charge Controller .....	10
2.6 E4 LCD Monitor .....	10
2.7 Kinergy Data Logging Stick .....	10
2.8 LS75 ESS unit .....	11
2.9 ES100 ESS unit .....	11
3.0 Functional Description .....	12
4.0 Installation .....	12
4.1 Material List .....	12
4.2 Location .....	13
4.3 Requirements of installation angle .....	13
4.4 Requirements of installation spacing .....	14
4.5 Fix the Cabinet .....	15
4.6 Wiring Recommendation .....	16
4.7 Connection Terminal Description .....	16
4.8 Wiring Instruction .....	17
5.0 Operation .....	20
5.1 Double Checking .....	20
5.2 Switching on the Battery .....	20
5.3 Switch on the Inverter .....	21
5.4 Power on PV .....	21
5.5 Power OFF .....	22
5.6 Bypass Switch Application .....	22
5.7 Connect to the NOVA Monitoring Platform .....	22
6.0 Configuration .....	23
7.0 Specification .....	24
Appendix 1: Battery Installation .....	26
Appendix 2: Introduction to cabinet parallel connection .....	27
1. Brief intro to AC distribution box .....	28
2. Overview of the DC Parallel Kit .....	29
3. Parallel connection .....	31
4. Description of precautions .....	41
5. Parameters setting for parallel connection .....	42

# 1.0 General Safety Instruction

## 1.1 Safety Instruction

As dangerous voltages and high temperature exist within the RAYTHON, only qualified and authorized maintenance personnel are permitted to open and repair it.

This manual contains information concerning the installation and operation of the RAYTHON. All relevant parts of the manual should be read prior to commencing the installation. Please follow the local stipulation meantime.

Any operation against safety requirement or against design, manufacture, safety standard, and are out of the manufacturer warranty.

## 1.2 Symbols Used in the Documentation



This symbol indicates a hazardous situation which, if not avoided, could result in death or serious injury.



This symbol indicates a situation which, if the instructions are not followed, could result in injury and damage to the equipment.



This symbol indicates a situation which, if the instructions are not followed, could result in damage to the equipment.

## 1.3 General Precaution



To avoid fire and electric shock, make sure all cables selected with right gauge and being connected well. Smaller diameter and broken cable are not allowed to use. Please do not put any inflammable goods near to RAYTHON.



Do not expose to dust, rain, snow or liquids of any type, it is designed for indoor use. DO NOT block off ventilation, otherwise the RAYTHON would be overheating.

## 1.4 Precaution Regarding Battery Operation

Only authorized and trained person who should be familiar to battery installation, preparation, charging, and maintenance is permitted to the operation for battery

**SHOCK HAZARD- DO NOT** touch the uninsulated battery connectors or terminals. Be sure to discharge static electricity of tools and technicians by touching a grounded surface, but away from the cells and flame arresters.

All tools should be adequately insulated to avoid the possibility of shorting connections.

**DO NOT** lay tools on the top of the battery.

Although the batteries are sealed and no gas emitted during normal operation, they contain potentially explosive gases, which may be released under abnormal operating conditions, such as a charger malfunction. It is the responsibility of the customer to provide adequate ventilation so that hydrogen gas accumulation in battery area does not exceed 2% by volume. However, normal air circulation in a ventilated facility will preclude any hydrogen build-up even during cyclic charging. Never install batteries in a sealed cabinet or enclosure.

**REMOVE** all personal metal items such as rings, bracelets, necklaces, and watches while working with batteries. Batteries can cause short-circuit current high enough to make metal melt, and could cause severe burns.



The battery contains sulfuric acid, which may lead to the burning of the severe. In case of skin touched the electrolyte, please remove contaminated clothing and flush affected areas thoroughly with water. If eye contact has occurred, flush for a minimum of 15 minutes with large amounts of running water and seek for immediate medical attention.

## 2.0 System Description

The Raython system is an all-in-one standalone solar power system. It is an ideal solution designed for holiday houses or single-family houses that have no access to the grid power and the users often use generators as their power supply. Featuring low pollution and low fuel consumption, it is also a perfect solution for people who pursue a more sustainable lifestyle.

The Raython system is expertly assembled, tested and shipped as a complete system, integrating a solar hybrid inverter or an inverter charger coupled with an MPPT solar charge controller, lithium battery modules, wireless data logger, and AC and DC power distribution into one system. On arrival, Raython system is ready to install and the all-in-one design makes it easy to install and saves your precious time.

Our Raython Solar System is designed for applications with a daily power use from 10kWh-20kWh, to meet your different power need.

### Features:

- All-in-one design for easy and quicker installation (<3 hours)
- Provided with IP54 protection index for outdoor use
- Factory assembled and tested system enable you get free from complicated groundwork
- ECO-friendly: lower pollution, less noise and lower fuel consumption
- AGS Function: automatically start and stop the generator according to the load level, battery level or time period to ensure continuous power supply in the case of insufficient PV power or system overload
- Leakage protect function on its AC output to ensure safety
- Power assist function enables the Raython power system to discharge its batteries to power heavy loads in conjunction with small generator, to prevent the overload on the AC Supply
- Strong ability to handle the spikes of the load initial current
- High performance system with strong overload capability, designed to power heavy loads like air-conditioner, water pump, fridge, washing machine, etc.
- NOVA Web & App system monitoring, to display real-time data of all system components and history record, to control the power generation and power consumption. According to historical data, users can actively adjust and optimize power consumption habits

## 2.1 Equipment layout

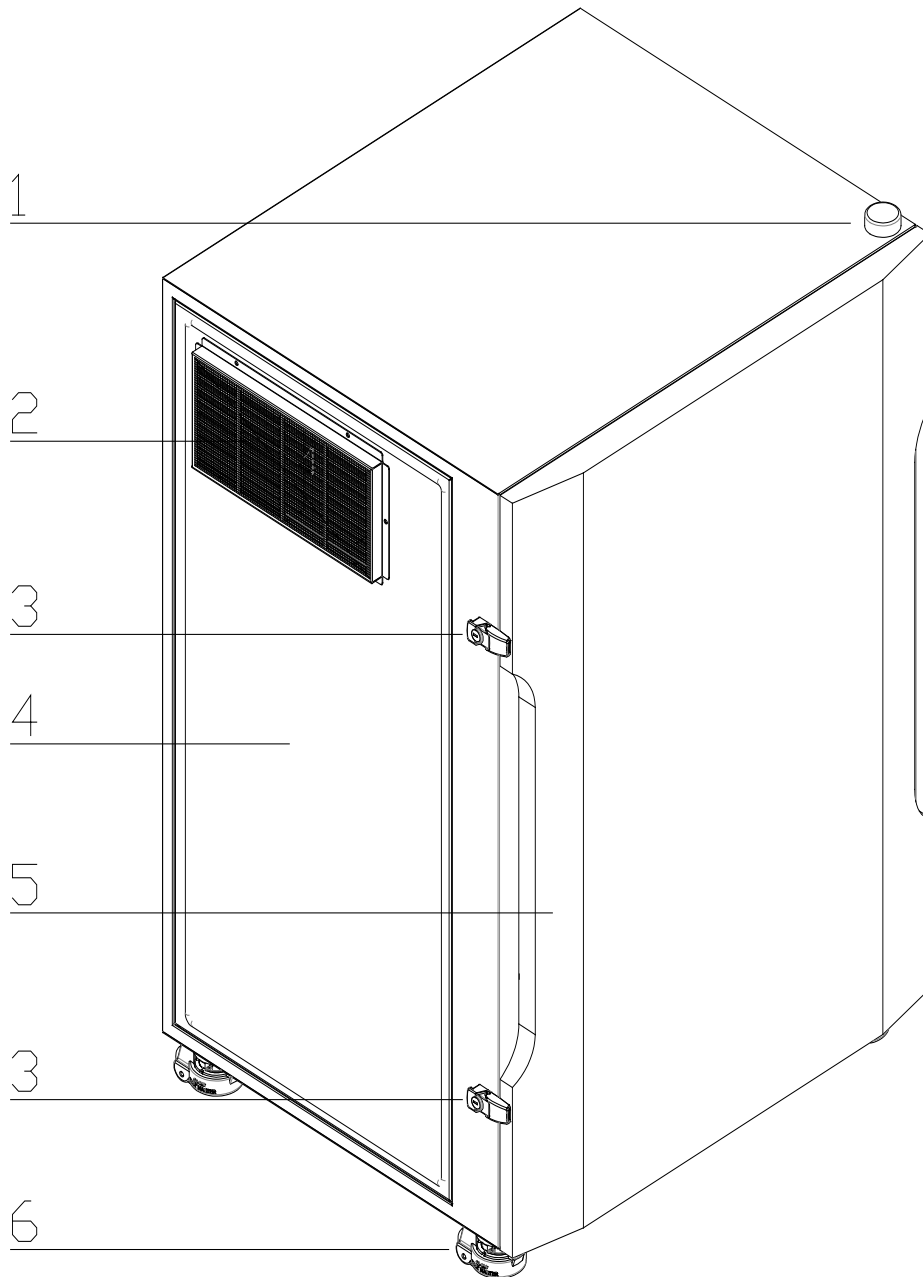

Raython Model 1&2

No.	Functional unit	No.	Functional unit
1	External antenna	2	Anti-dust mesh cover
3	Cabinet front door lock	4	Battery compartment door
5	Cabinet front door	6	Caster

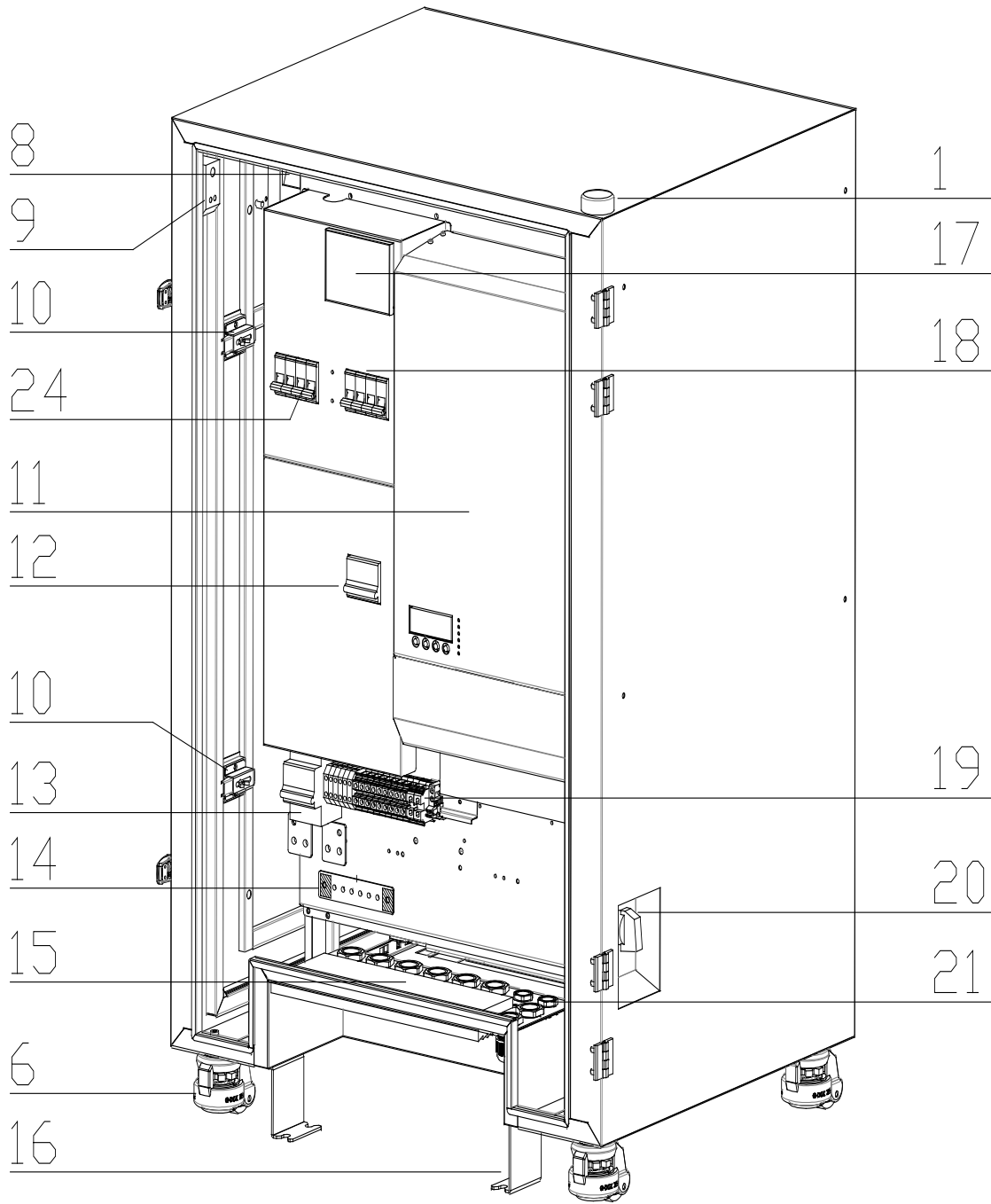

Raython Model 0&1

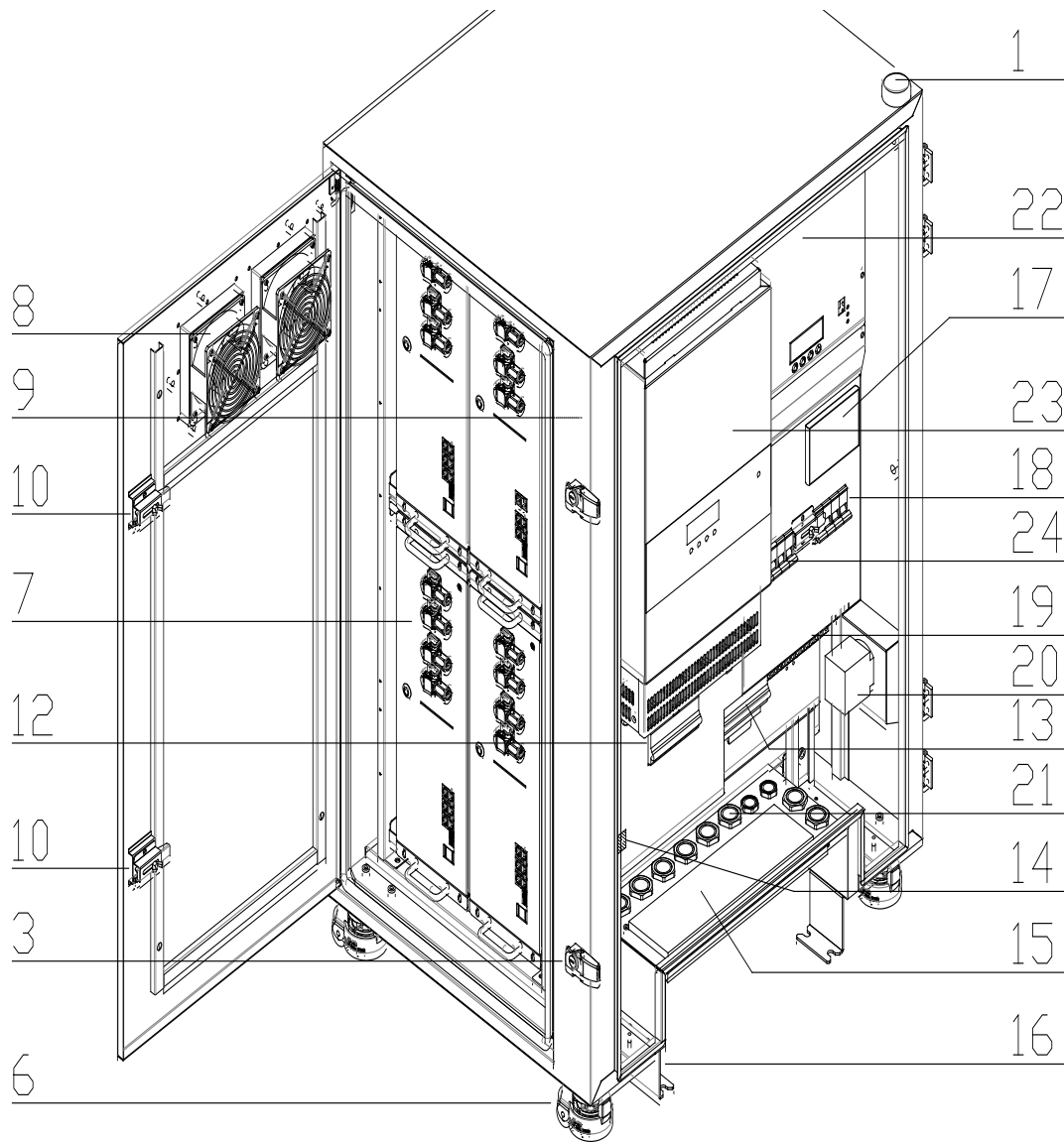

Raython Model 2

No.	Functional unit	No.	Functional unit
7	Lithium battery	8	Cooling fan
9	Cooling fan temperature control switch	10	Battery compartment door lock
11	Apollo Matrix 3.0S or Apollo Matrix 5.0S	12	Internal battery circuit breaker
13	External battery circuit breaker (optional)	14	Ground copper bar
15	Air inlet louvers	16	Structural parts for cabinet fixing
17	E4 LCD Monitor	18	AC circuit breaker
19	External wiring terminal	20	PV input isolate switch
21	Inlet and outlet holes for cables	22	SP150-120 Solar Charge Controller
23	Kinergie Pro CK8.0S Inverter Charger	24	Manual maintenance switch padlock

## 2.2 Raython Cabinet Dimensions

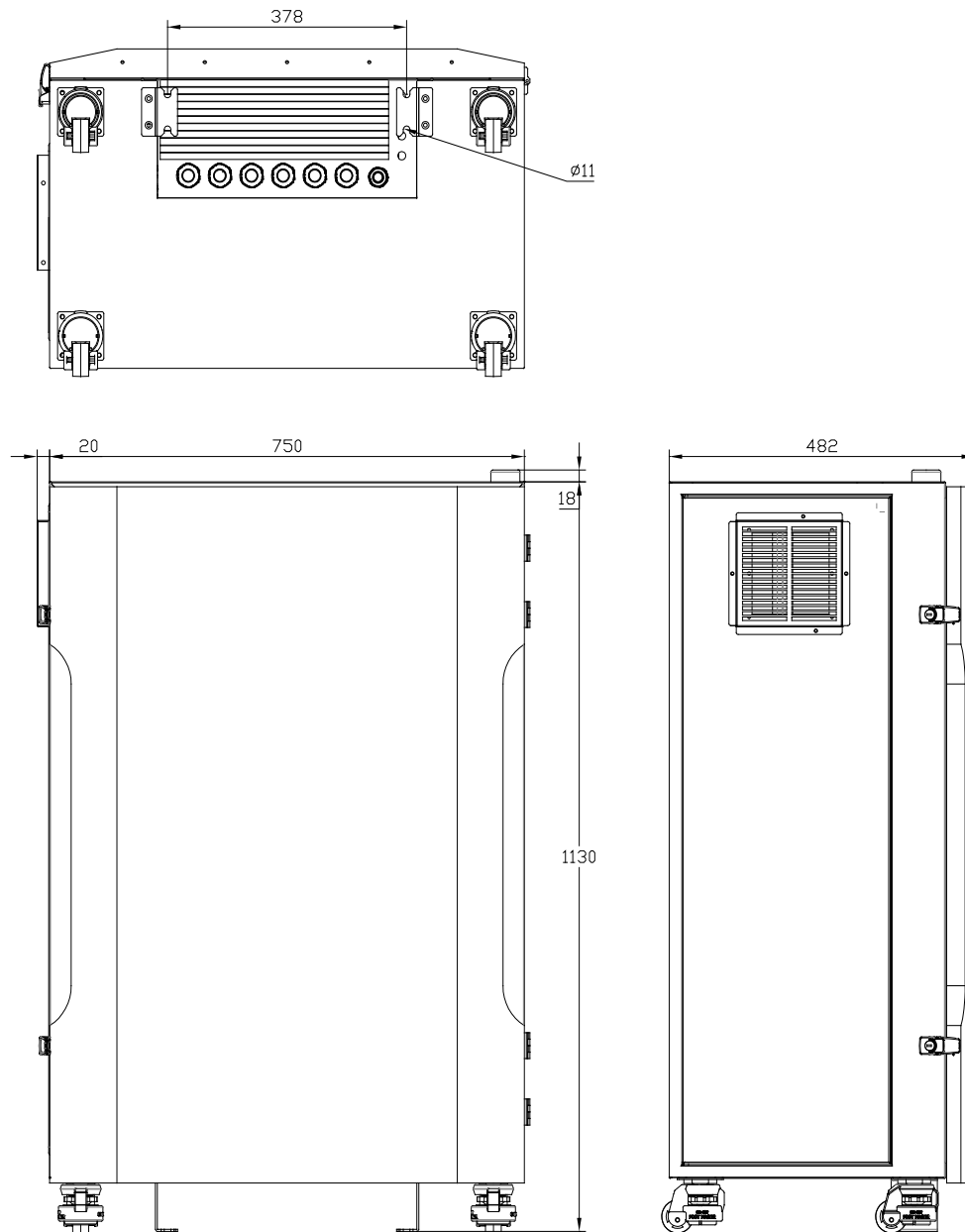

Raython Model 0

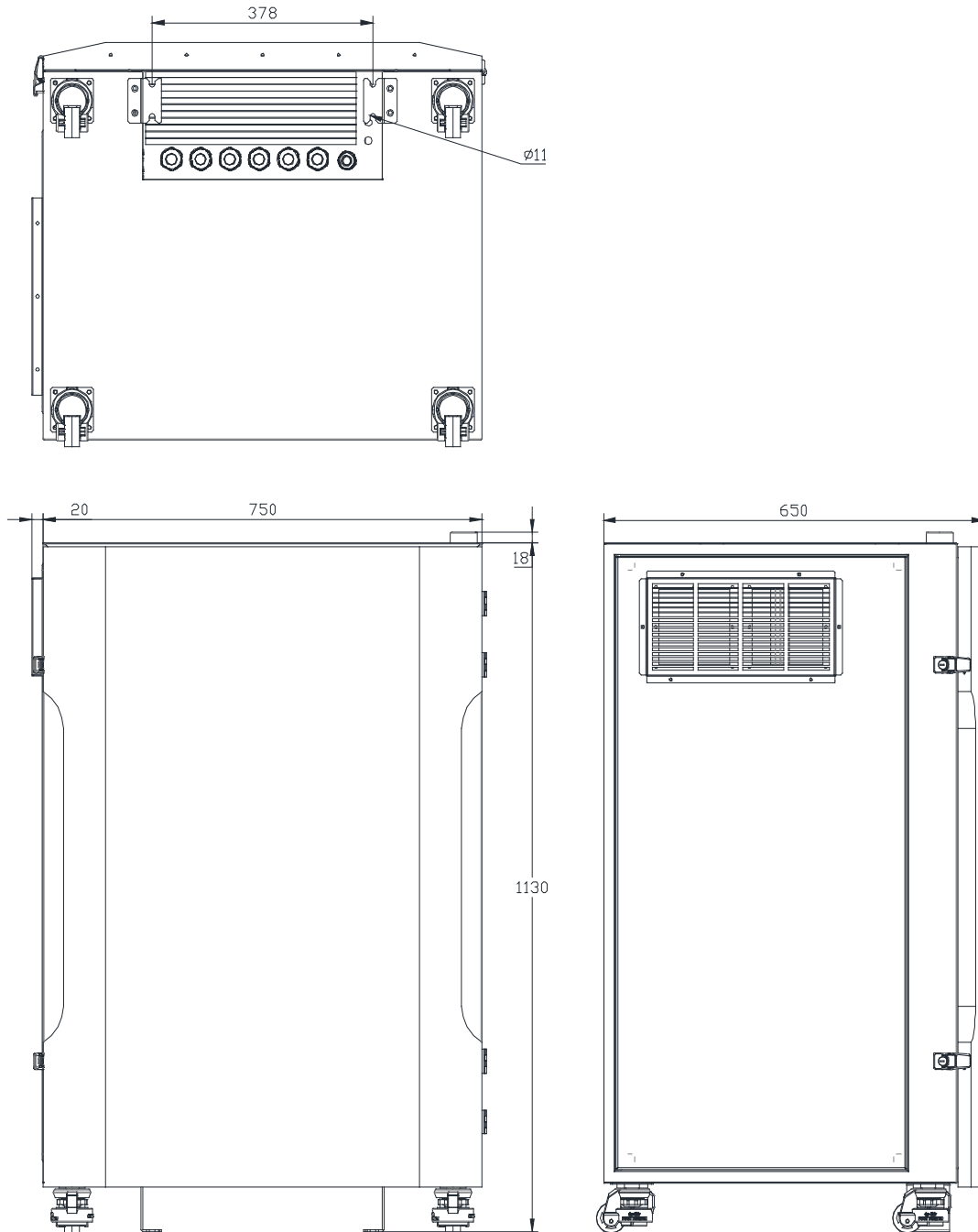

Raython Model 1&2

### 2.3 Apollo Matrix Solar Hybrid Inverter

Apollo Matrix is the new generation solar hybrid inverter designed for various types of off-grid systems including the AC Couple system, DC Couple system, and generator hybrid system. It can provide UPS class switching speed and support parallel as well as composing three-phase system.

Apollo Matrix delivers high reliability, performance, and industry-leading efficiency for mission-critical application. Its distinguishing surge capability makes it capable to power most demanding appliances, such as air conditioner, water pump, washing machine, freezer, etc.

With the function of power assist & power control, it can be used to work with a limited AC source such as generator or limited grid. Apollo Matrix can automatically adjust its charging current to avoid the grid or generator being overloaded. In case of temporary peak power appears, it can work as the supplement source to the generator or grid.

For more information about Apollo Matrix, please refer to its manual.



## 2.4 Kinergier Pro Inverter Charger

Kinergier Pro is the new generation inverter charger designed for various type of off grid system including AC Coupled PV System, DC Coupled PV System and generator hybrid system. It can provide UPS class switching speed and capability to support parallel as well as composing three phase system.

Kinergier Pro delivers high reliability, performance and industry leading efficiency for mission critical application. Its distinguishing surge capability makes it capable to power most demanding appliances, such as air conditioner, water pump, washing machine, freezer etc.

With the function of power assist & power control, it can be used to work with a limited AC source such as generator or limited grid. Kinergier Pro can automatically adjust its charging current to avoid grid or generator to be overloaded. In case of temporary peak power appears, it can work as a supplement source to generator or grid

For more information about Kinergier Pro, please refer to its manual.



## 2.5 Solar Mate MPPT Charge Controller

SP is a solar charge controller with built-in Maximum Power Point Tracking (MPPT) technology, which can optimize the PV's output eliminate the fluctuation due to shading or temperatures variables. It tracks the maximum power point of a PV array to deliver the maximum charging current for battery, enabling PV array to increase the output by as much as 30% compared with PWM design.

SP is a multi-voltage MPPT with built-in sophisticated battery charging algorithm for various kinds of lead acid batteries, including AGM, GEL, Traction. Data management with a year of history record was offered as well. Meantime, version for Lead-Carbon battery and lithium ion battery were available upon request.

For more information about Solar Mate, please refer to its manual.



## 2.6 E4 LCD Monitor

TBB E4 is all intelligent central LCD touch monitor, providing intuitive, local and real-time control and monitoring for TBB systems, but it is applicable to different systems. For TBB off-grid systems and residential energy storage systems.

Meanwhile, it is connect the system to the TBB NOVA online portal for remote system monitoring.

For more information about E4, please refer to its manual.



## 2.7 Kinergy Data Logging Stick

Available with GPRS and WIFI version, wireless data logger is an external communication device connected to the TBB inverter through DB9 interface. Through NOVA web or APP, it offers a convenient way to monitor the system performance remotely.

One Kinerigy module can monitor up to 6 inverters, 6 Solar Mate MPPT solar charge controller and 2 IG PV inverter at the same time. It is widely applied with most inverter series of TBB Power, such as Kinerigy Pro, Apollo Maxx, Apollo Matrix, RiiO and RiiO Sun.

For more information about Kinerigy, please refer to its manual.



## 2.8 LS75 ESS unit

LS75 lithium iron phosphate battery system is a standard battery system unit, customers can choose a certain number of LS75 according to their needs, through parallel connection to form a larger capacity battery storage, to meet the user's long-term power supply needs. The product is especially suitable for applications under high operating temperatures, limited installation space, long power backup time and long service life.



## 2.9 ES100&ES100 II ESS unit

ES100&ES100 II is the latest 48V 105Ah lithium battery module provided by TBB POWER, designed for backup power system, solar grid system, and residential, industrial & commercial energy storage systems, with good compatibility, high energy density, fashionable design and safe long cycling life.



### 3.0 Functional Description

Raython is composed of Inverter, MPPT charge Controller, Kinergy, and Li-ion battery modules. As following diagram shows, through monitoring the real-time output power, energy consumption of the connected appliances and the battery SOC, Raython will automatically change the work mode to keep your loads being powered.

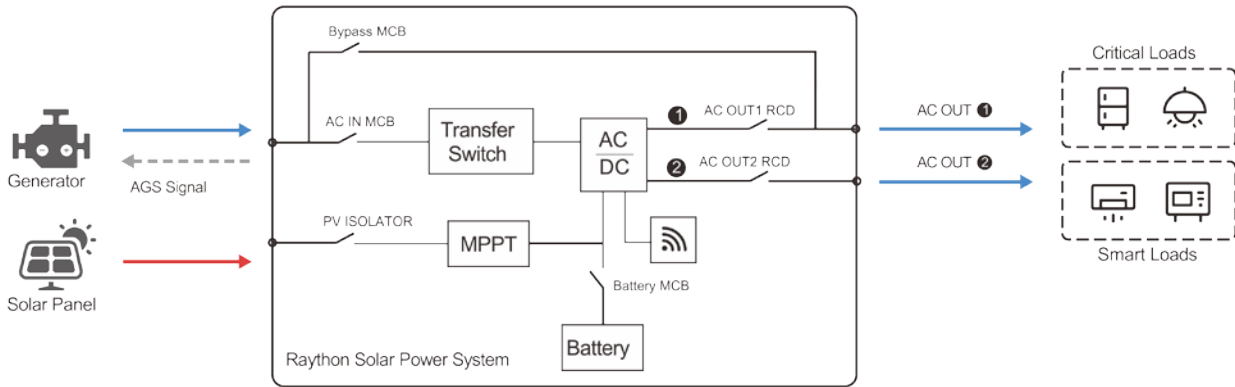

### 4.0 Installation

#### Prior to Installation

- Read the manual carefully and confirm the voltage and current input requirements of the load(s) are compatible with the unit’s output.
- Also see the line voltage and current is compatible with the unit’s input requirements.
- Wiring should be done to meet local electrical codes.

Use proper lifting techniques when lifting installing or moving the unit.

#### 4.1 Material List

The unit is packed with following materials. Please confirm the series number on the inverter is the same to that on the outer carton.

- Raython
- Raython User manual
- Kinergy/E4 User manual
- Apollo Matrix User manual/Kinergier Pro User manual/Solar Mate User manual

## 4.2 Location

Please install the equipment in a location of Dry, Clean, Cool with good ventilation.

- Working temperature: -20°C-60°C
- Storage temperature: -40-70°C
- Relative Humidity: 0%-95%, non-condensing
- Cooling: Forced air



Keep it away from fire, high temperature, inflammable; explosive or corrosive material.

- Raython system is designed for outdoor usage. Install the system at the locations away from direct sunlight, rain or damp.
- The system should be installed at dry, clean, well ventilated environment. Away from dust and garbage.
- Guarantee the enough clearance of installation. Good ventilation is critical for proper performance of system.

## 4.3 Requirements of installation angle

Equipment should be installed on a flat surface.



- Do not place the unit in an inclined position.
- Do not store the unit on its side or up-side down to avoid the damage of the unit.

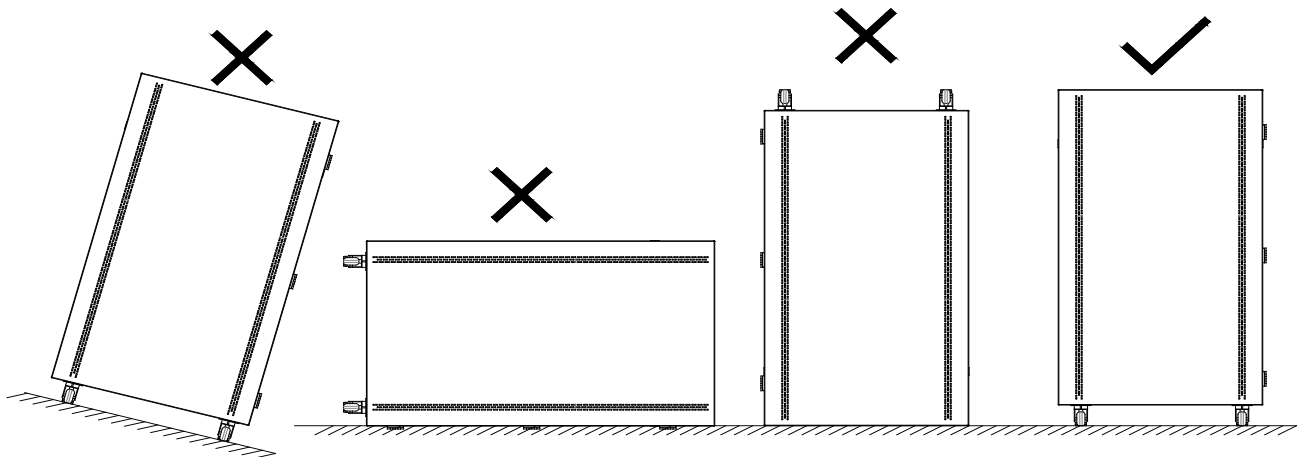

### 4.4 Requirements of installation spacing

Following minimum clearance are requested for the installation.

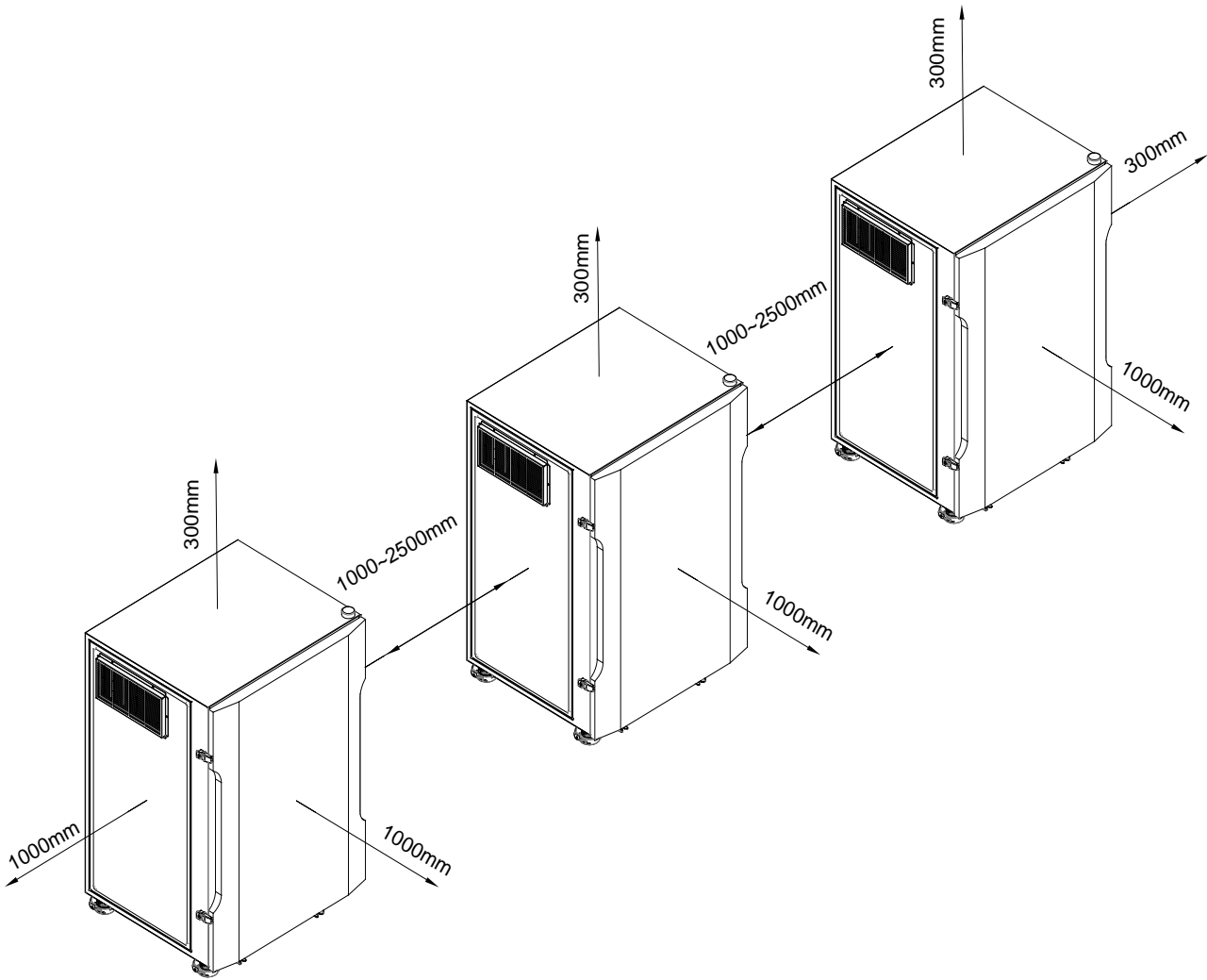

Direction	Minimum Clearance
Front	1m
Left Side	0.3m
Right Side	1m
Top	0.3m
distance between cabinets	1m~2.5m

## 4.5 Fix the Cabinet

- Rotate the four casters of the Raython cabinet counterclockwise so that the bottom plate of the casters will be overhanging.
- Refer to the fixed bracket of the Raython cabinet as shown in the figure.
- Pre-bury M10 screw or expansion bolt according to the fixing hole size.
- Push the Raython cabinet to align the slot on the fixed bracket with the pre-buried screw.
- Rotate the four casters of the Raython cabinet clockwise, so that the bottom plate of the casters falls to the ground (Rotating the nut A clockwise as shown at the right picture with a spanner or other proper tool)
- Use M10 nut to fix the installation bracket of the Raython cabinet with the pre-buried screws

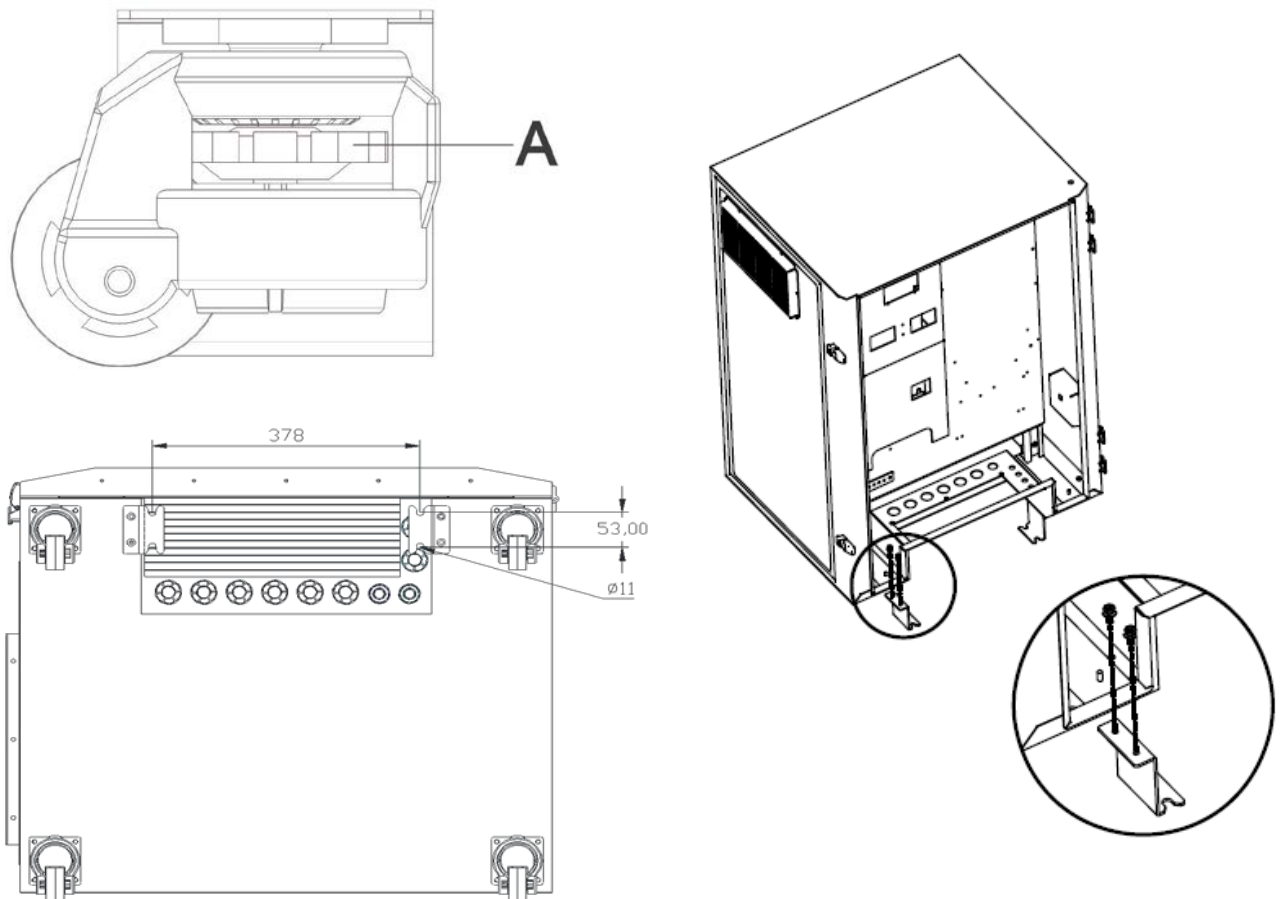

### 4.6 Wiring Recommendation

Please find the following minimum wire size. In case of DC cable longer than 5m, please increase the cross section of the cable to reduce the loss.

Item	Raython Model 0		Raython Model 1		Raython Model 2	
	Cable Size	Circuit Breaker	Cable Size	Circuit Breaker	Cable Size	Circuit Breaker
AC input	6mm <sup>2</sup>	32A	10mm <sup>2</sup>	50A	10mm <sup>2</sup>	50A
AC output	6mm <sup>2</sup>	32A	10mm <sup>2</sup>	50A	10mm <sup>2</sup>	50A
PV input	10mm <sup>2</sup>	40A	16mm <sup>2</sup>	60A	25mm <sup>2</sup>	80A
AGS cable	1 mm <sup>2</sup>	-	1 mm <sup>2</sup>	-	1 mm <sup>2</sup>	-
External Battery	-	-	25mm <sup>2</sup>	125A	50mm <sup>2</sup>	250A

### 4.7 Connection Terminal Description

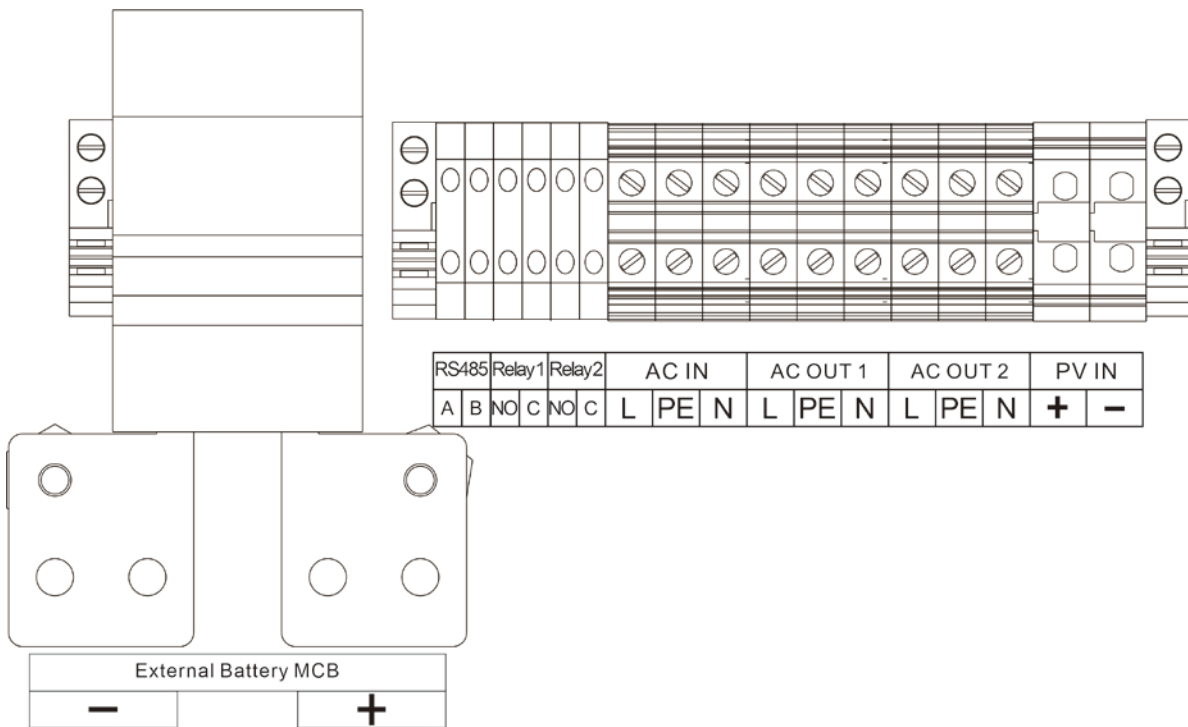

Item	Name	Description	Label	Comments
1	RS485	Upper computer communication	A	
			B	
2	Relay1&2	Connect to generator start control port	NO	Normally Open
			C	Common
3	AC IN	Connect to the grid AC input	L	Line
			PE	Protecting Earthing
			N	Neural
4	AC OUT 1	General load without being protected by installed MCB	L	Line
			PE	Protecting Earthing
			N	Neural
5	AC OUT 2	General load without being protected by installed MCB	L	Line
			PE	Protecting Earthing
			N	Neural
6	PV IN	Loads controlled being protected by installed PV switch	+	Positive
			-	Negative
7	External Battery	External battery pack terminal (optional accessory for cabinet parallel connection)	+	Positive
			-	Negative

### 4.8 Wiring Instruction

All of the cables should be inserted into the cabinet through the holes at the bottom of the cabinet as below picture shows.





Cut off the power before installation for safety. Please make sure the inverter is switched off and DC MCB is turn off at front panel before installation.

### 4.8.1 Connecting to Earth

At the bottom of the enclosure, there is a ground terminal. See wiring area view. Please connect it with EARTH or vehicle chassis by a 6~10mm<sup>2</sup> green yellow wire (keep wire size same with AC input cable).

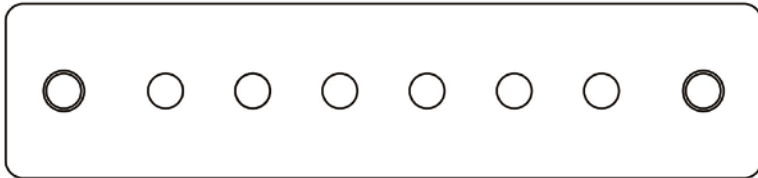

### 4.8.2 Connecting AC Grid Cable



For safety, please turn off the Main Input MCB before the installation

Using correct cable gauge (refer to chapter 4.6), please connect the grid to the terminal labeled “AC IN”. Make sure the connection is correct and tightly screwed.

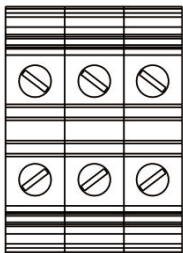

### 4.8.3 Connecting the Loads



Do not connect the output of this equipment to the same line as other AC sources such as the 230V external mains or a generator.

Two groups of output terminals are supplied with this RAYTHON system. The labeled terminal is supplied with protected MCB.

Using correct cable gauge (refer to chapter 4.6), please connect the load to the terminal labeled “AC OUT1” “AC OUT2”. Make sure the connection is correct and tightly screwed.

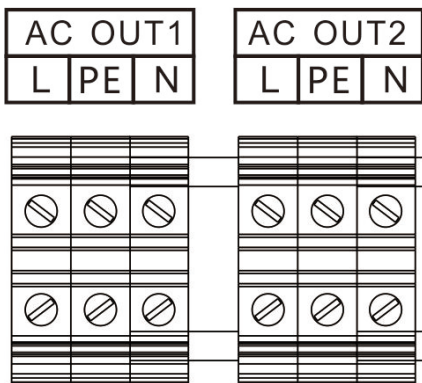

### 4.8.4 Connecting PV in Cable



For safety, please turn off the PV Input MCB before the installation.

Using correct cable gauge (refer to chapter 4.6), please connect the PV to the terminal labeled “PV IN”. Ensure that the positive and negative poles are not reversed. Make sure the connection is correct and tightly screwed.

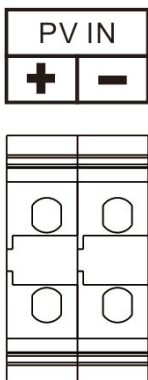

### 4.8.5 Connecting the AGS Terminal

Two groups of AGS terminals are supplied with this RAYTHON system.

Using correct cable gauge (refer to chapter 4.6), please connect the Generator to the terminal labeled "Relay1" "Relay2". Make sure the connection is correct and tightly screwed.

Relay 1		Relay 2	
NO	C	NO	C

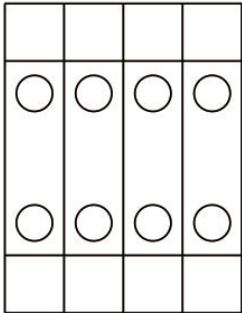

## 5.0 Operation

### 5.1 Double Checking

- The system is installed correctly and steady.
- Make sure the ground wire is properly connected firmly and reliably.
- Make sure the cables are properly connected firmly and reliably.
- The DC breaker AC breaker and PV switch is OFF before switching on the inverter
- Inspect the Ac input and AC output are correct, and make sure the unit is not short cut.
- Make sure the AC input voltage is within the nominal range.
- Make sure the PV input voltage is within the nominal range

### 5.2 Switching on the Battery

- Make sure the battery voltage is within the permissible range before turning ON the breaker.
- Switch on all batteries. please refer to its manual
- Switch on battery switch

### 5.3 Switch on the Inverter

Please follow the below instructions step by step.

- Step 1: Press the On/Off button for 2 seconds to turn on the inverter into the standby mode, the power LED will light up and the LCD will enter the self diagnostic mode.
- Step 2: Wait in the standby mode for 30 seconds, then press the On/Off button again for 1 second to turn on the inverter into the inverting mode and observe the LCD and the invert LED to make sure the inverter is running normally.



Apollo Matrix interface

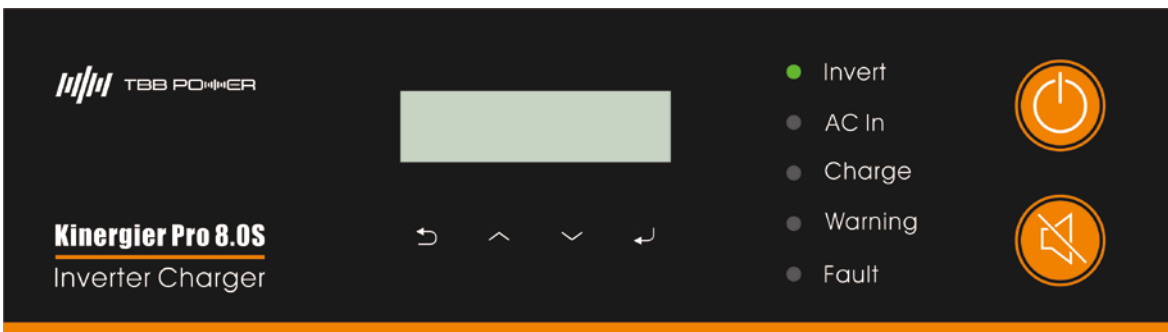

Kinergier Pro interface

### 5.4 Power on PV

- Close the PV IN Switch to power
- The MPPT Charge Controller will start to charge the battery.

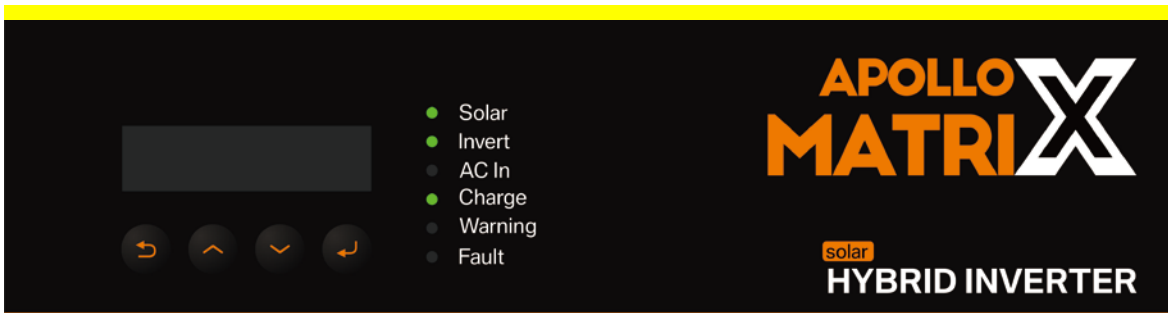

Apollo Matrix interface

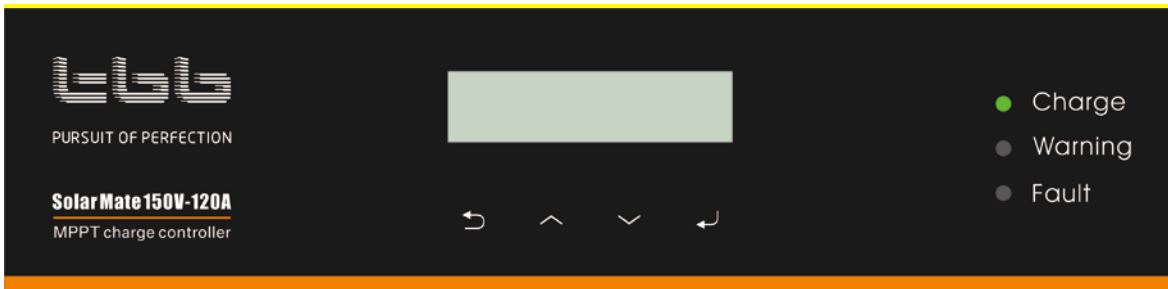

Solar Mate interface

## 5.5 Power OFF

- Step 1: When the inverter is in the inverting mode or charging mode, press the On/Off button for 2 seconds to turn off the inverter into the standby mode.
- Step 2: When the inverter is in the standby mode, press the On/Off button for 5 seconds to turn off the inverter into the complete off mode.
- Step 3: Turn off the circuit breaker of PV input and AC input.
- Step 4: Turn off the circuit breaker between the battery and the inverter.

## 5.6 Bypass Switch Application

When the system fails to supply power, you can use this switch to supply power to the load from the grid or generator.

The power is only supplied to the load connected to the AC OUT1.

- Step 1: turn off the AC OUT1 and AC input break
- Step 2: turn off the battery switch and the PV in switch
- Step 3: Release the baffle switch and push the baffle switch to the AC OUT1 side
- Step 4: Close the Bypass switch

## 5.7 Connect to the NOVA Monitoring Platform

Please refer to the User Manual of Kinergy/E4 and Quick Installation Guide

more details, please visit [www.tbbrenewable.com](http://www.tbbrenewable.com)

## 6.0 Configuration

### Standard Setting

Setting	Value
Rated AC Voltage	230VAC
Rated AC frequency	50Hz
AC in source Selection	Generator
Input frequency range	45-55Hz
Input voltage range	175-265VAC
AC Wave Harmonic Adaption	Weak AC Source
Battery Type	TBB Super-L
SOC Low Protect	10%
SOC Low Warning	20%
SOC charge Enough	80%
AC in Logic	AC in First mode
AC OUT2 Control	Power By AC in
Relay Control	AGS Function
GEN Start SOC	30%
GEN Stop SOC	80%
GEN load control	Disable
GEN Time Window	Disable
Relay 1 signal type	Level
Relay 2 signal type	Pulse

For more settings, please refer to its manual.

## 7.0 Specification

Model	Raython Model 0	Raython Model 1	Raython Model 2
<b>AC input</b>			
Generator compatible	Yes		
AC input voltage range (VAC)	175~265		
AC input Frequency range (Hz)	45~65		
AC input Current (transfer switch) (A)	32	50	50
<b>Inverter</b>			
Product Topology	Transformer based		
Nominal battery voltage (VDC)	48		
Input voltage range (VDC)	42~68		
AC output voltage (VAC)	220/230/240 ± 2%		
AC output frequency (Hz)	50/60 ± 0.1%		
Harmonic distortion	<2%		
Load power factor	1.0		
Cont. output power at 25°C (W)	3000	5000	6500
Max output power at 25°C (W)	3000	5000	8000
Peak power (W)	9000	15000	16000
Maximum efficiency	95%	96%	96%
Zero load power (W)	14	18	26
Max AC charge current (A)	40	70	110
Main Output (AC Out1) Current (A)	32	50	
Transfer time	<2ms (<15ms in Weak AC source Mode)		
<b>PV in</b>			
Max output current(A)	60	90	120
Maximum PV power(W)	4000	6000	9000
PV open circuit voltage (V)	150		
Maximum PV short circuit Current(A)	35	54	80
MPPT voltage range(V)	65~145		
MPPT charger maximum efficiency	98%		
MPPT efficiency	>99.5%	>99.5%	>99.9%

Model	Raython Model 0	Raython Model 1	Raython Model 2
<b>Battery</b>			
Battery Type	LiFePO4 Li-ion battery		
Nominal Energy Capacity	5.1kWh-20.4kWh	10.2kWh-20.4kWh	
<b>General data</b>			
General purpose com. Port	WIFI optional with E4		
Operating temperature range	Inverter: -20°C to 65°C Battery: discharge -20°C to 55°C, charge 0-40°C		
Relative humidity in operation	95% without condensation		
Altitude (m)	2000		
<b>Mechanical Data</b>			
Dimension ( W*D*H ) (mm) (max)	750*482*1130	750*650*1130	
Net Weight (kg) (without battery)	120kg	135kg	150kg
Cooling	Forced fan		
Protection index	IP54		
<b>Standards</b>			
Safety	EN-IEC 62477-1, EN-IEC 62109-1, EN-IEC 62109-2		EN-IEC 60950-1, EN-IEC 62109-2
EMC	EN61000-6-1, EN61000-6-2, EN61000-6-3, EN61000-3-11, EN61000-3-12		

## Appendix 1: Battery Installation

The battery compartment of Raython System is designed according to two types of lithium batteries: ES100 and LS75, based on their respective dimensions. Raython Model 0 can accommodate a maximum of two ES100 or LS75 batteries, while Raython Model 1&2 can accommodate a maximum of four ES100 or LS75 batteries.

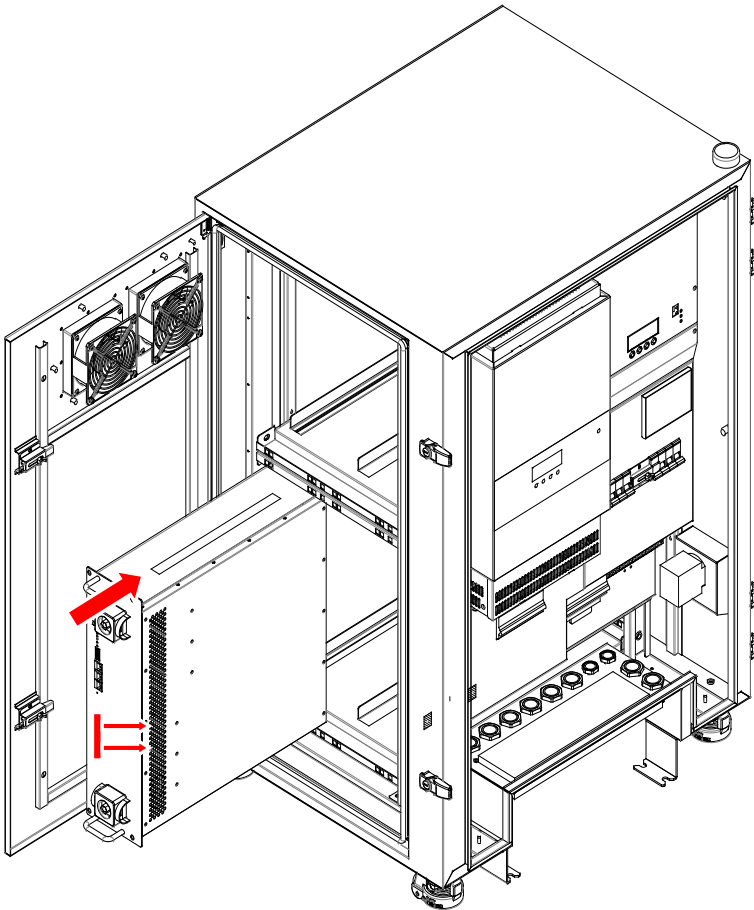

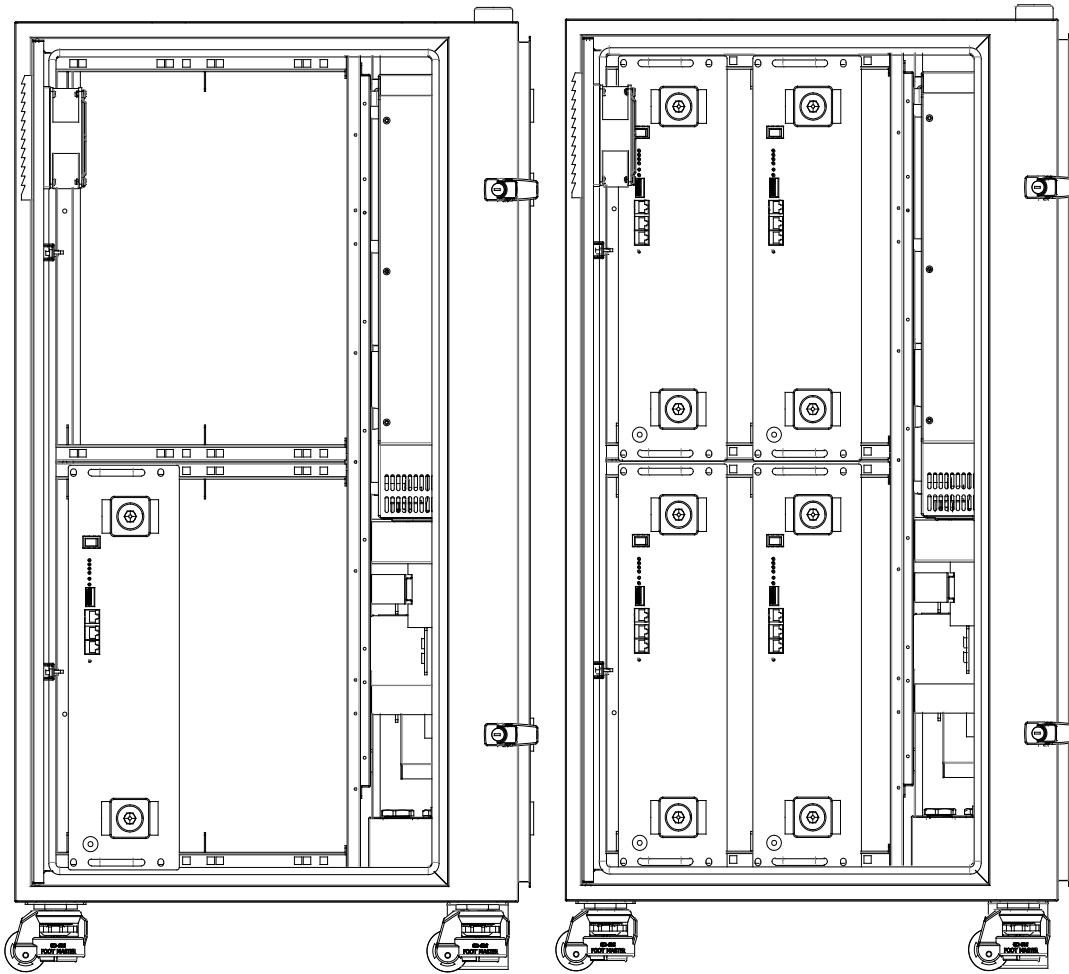

## Appendix 2: Introduction to cabinet parallel connection

Raython series support parallel connection of up to 3 cabinets of the same type in three-phase or single-phase parallel to expand the system capacity. Before conducting the parallel connection, it is necessary to purchase the accessories listed on the following table based on the actual need.

Model	Parallel Connection Requirement	AC Distribution Box	DC Parallel Kit
Raython Model 1	Two cabinets in parallel and single-phase	1*PDU-M2-3S	KIT-M1-2P
	Three cabinets in parallel and single-phase	1*PDU-M2-3S	KIT-M1-3P
	Three cabinets in three-phase	1*PDU-M2-3T	KIT-M1-3P
Raython Model 2	Two cabinets in parallel and single-phase	1*PDU-M2-3S	KIT-M2-2P
	Three cabinets in parallel and single-phase	1*PDU-M2-3S	KIT-M2-3P
	Three cabinets in three-phase	1*PDU-M2-3T	KIT-M2-3P

## 1. Brief intro to AC distribution box

1.1 PDU-M2-3T is a customized AC distribution box for Raython Model 1&2 parallel and three-phase connection use, featuring wall mount, IP54, 400V/63A, and output surge protection level II.



PDU-M2-3T External View

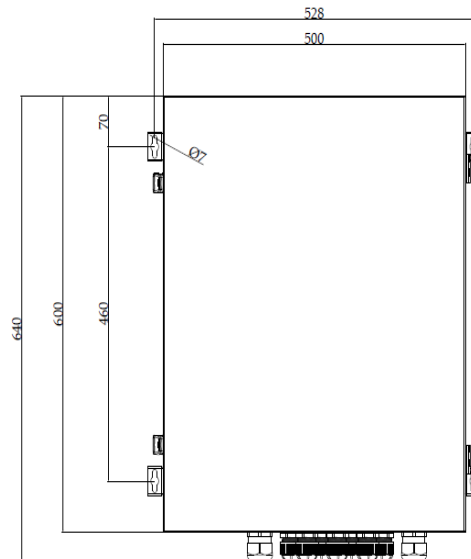

PDU-M2-3T External Size Drawing

1.2 In the Raython parallel system, PDU-M2-3T AC distribution box is fixed on the right side of the host cabinet of Raython Model 1&2 with 4 M6\*12 screws.

1.3 Please refer to the information package delivered with the distribution box or the electronic information provided by the manufacturer after-sale division for the detailed electrical schematic diagram of PDU-M2-3T AC distribution box.

1.4 PDU-M2-3S is a customized AC distribution box for Raython Model 1&2 single-phase parallel connection, featuring wall mount, IP54, 230V/125A, and output surge protection level II.



PDU-M2-3S External View

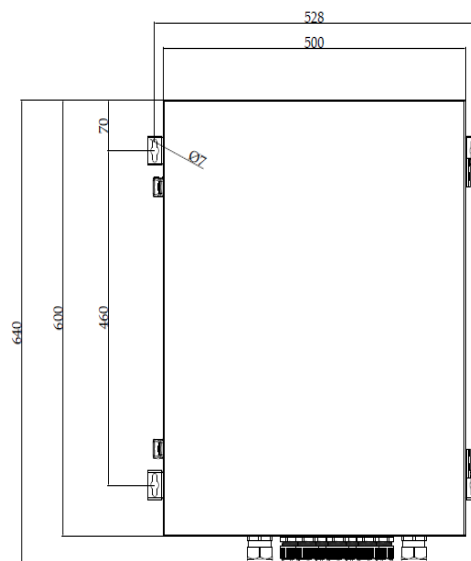

PDU-M2-3S External Size Drawing

**1.5** In the Raython parallel system, PDU-M2-3S AC distribution box is fixed on the right side of the host cabinet of Raython Model 1&2 with 4 M6\*12 screws.

**1.6** Please refer to the information package delivered with the distribution box or the electronic files provided by the manufacturer after-sale division for the detailed electrical schematic diagram of PDU-M2-3S AC distribution box.

## 2. Overview of the DC Parallel Kit

### 2.1 KIT-M1-2P

Raython Model 1 DC Parallel Kit for two cabinets parallel connection:

No.	Item	Quantity
1	DC MCB, NDB6Z-125C125/2, 2P, Type C	2
2	Copper terminal strip used for extending the phase line output of DC MCB	4
3	Screw, M8*15mm, hexagonal shape with two gaskets	8
4	System communication cable, UTP, 4PR, 8P8C, 5m	2
5	Power cable, BVR, 25mm <sup>2</sup> , red, 330mm, GT25-8&E25-16 terminal	2
6	Power cable, BVR, 25mm <sup>2</sup> , black, 240mm, GT25-8&E25-16 terminal	2
7	Self-made power cable, BVR, 25mm <sup>2</sup> , black, 3m, GT25-8x2 terminal	1
8	Self-made power cable, BVR, 25mm <sup>2</sup> , red, 3m, GT25-8x2 terminal	1

Note: The items might not conform to the ones listed above with regard to the actual need of cabinets parallel connection and will subject to change without prior notice.

### 2.2 KIT-M1-3P

Raython Model 1 DC parallel kit for three cabinets parallel connection:

No.	Item	Quantity
1	DC MCB, NDB6Z-125C125/2, 2P, Type C	3
2	Copper terminal strip used for extending the phase line output of DC MCB	6
3	Screw, M8*15mm, hexagonal shape with two gaskets	12
4	System communication cable, UTP, 4PR, 8P8C, 5m	4
5	Power cable, BVR, 25mm <sup>2</sup> , red, 330mm, GT25-8&E25-16 terminal	3
6	Power cable, BVR, 25mm <sup>2</sup> , black, 240mm, GT25-8&E25-16 terminal	3
7	Self-made power cable, BVR, 25mm <sup>2</sup> , black, 3m, GT25-8x2 terminal	2
8	Self-made power cable, BVR, 25mm <sup>2</sup> , red, 3m, GT25-8x2 terminal	2

Note: The items might not conform to the ones listed above with regard to the actual need of cabinet parallel connection and will subject to change without prior notice.

### 2.3 KIT-M2-2P

Raython Model 2 DC parallel kit for two cabinets parallel connection:

No.	Item	Quantity
1	DC MCB, NDB6Z-125C125/4, 4P, Type C	2
2	Copper terminal strip used for extending the phase line output of DC MCB	8
3	Screw, M8*15mm, hexagonal shape with two gaskets	16
4	System communication cable, UTP, 4PR, 8P8C, 5m	2
5	System communication cable, UTP, 2PR, 4P4C,5m	1
6	Power cable, BVR, 25mm <sup>2</sup> , red, 450mm, GT25-8x2 terminal	4
7	Power cable, BVR, 25mm <sup>2</sup> , black, 450mm, GT25-8x2 terminal	4
8	Self-made power cable, BVR, 50mm <sup>2</sup> , black, 3m, GT50-8x2 terminal	1
9	Self-made power cable, BVR, 50mm <sup>2</sup> , red, 3m, GT50-8x2 terminal	1

Note: The items might not conform to the ones listed above with regard to the actual need of cabinet parallel connection and will subject to change without prior notice

### 2.4 KIT-M2-3P

Raython Model 2 DC parallel kit for three cabinets parallel connection:

No.	Item	Quantity
1	DC MCB, NDB6Z-125C125/4, 4P, Type C	3
2	Copper terminal strip used for extending the phase line output of DC MCB	12
3	Screw, M8*15mm, hexagonal shape with two gaskets	24
4	System communication cable, UTP, 4PR, 8P8C, 5m	4
5	System communication cable, UTP, 2PR, 4P4C,5m	2
6	Power cable, BVR, 25mm <sup>2</sup> , red, 450mm, GT25-8x2 terminal	6
7	Power cable, BVR, 25mm <sup>2</sup> , black, 450mm, GT25-8x2 terminal	6
8	Self-made power cable, BVR, 50mm <sup>2</sup> , black, 3m, GT50-8x2 terminal	2
9	Self-made power cable, BVR, 50mm <sup>2</sup> , red, 3m, GT50-8x2 terminal	2

Note: The items might not conform to the ones listed above with regard to the actual need of cabinet parallel connection and will subject to change without prior notice.

### 3. Parallel connection

3.1 Partial layout diagram of the electrical components and connecting terminals location in the Raython Model 1 for cabinet parallel connection:

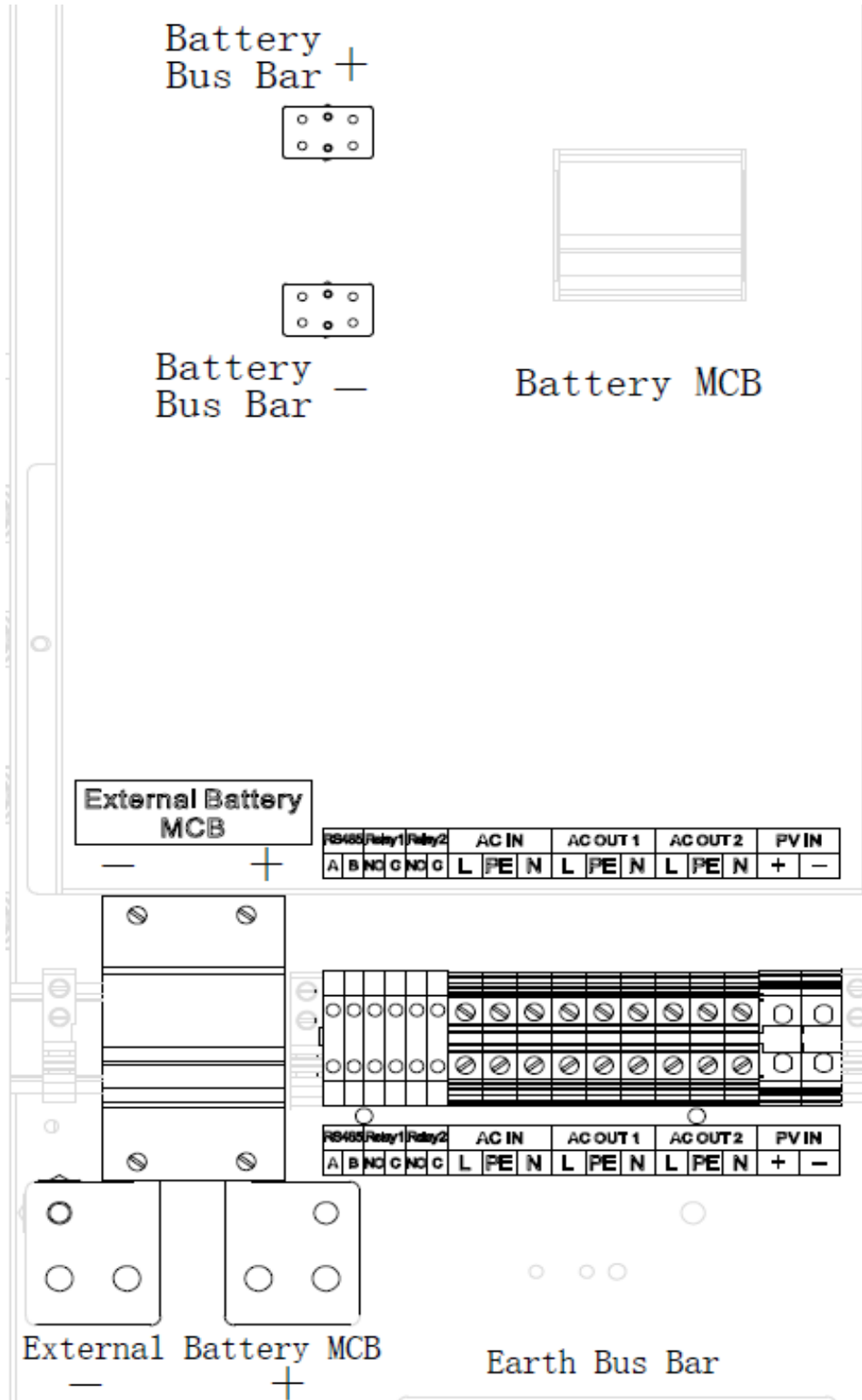

### 3.2. Brief intro to the connection of power cable for Raython Model 1 cabinets parallel connection:

#### 3.2.1 Diagram on AC & DC power cables wiring connection for two Raython Model 1 parallel connection in single-phase.

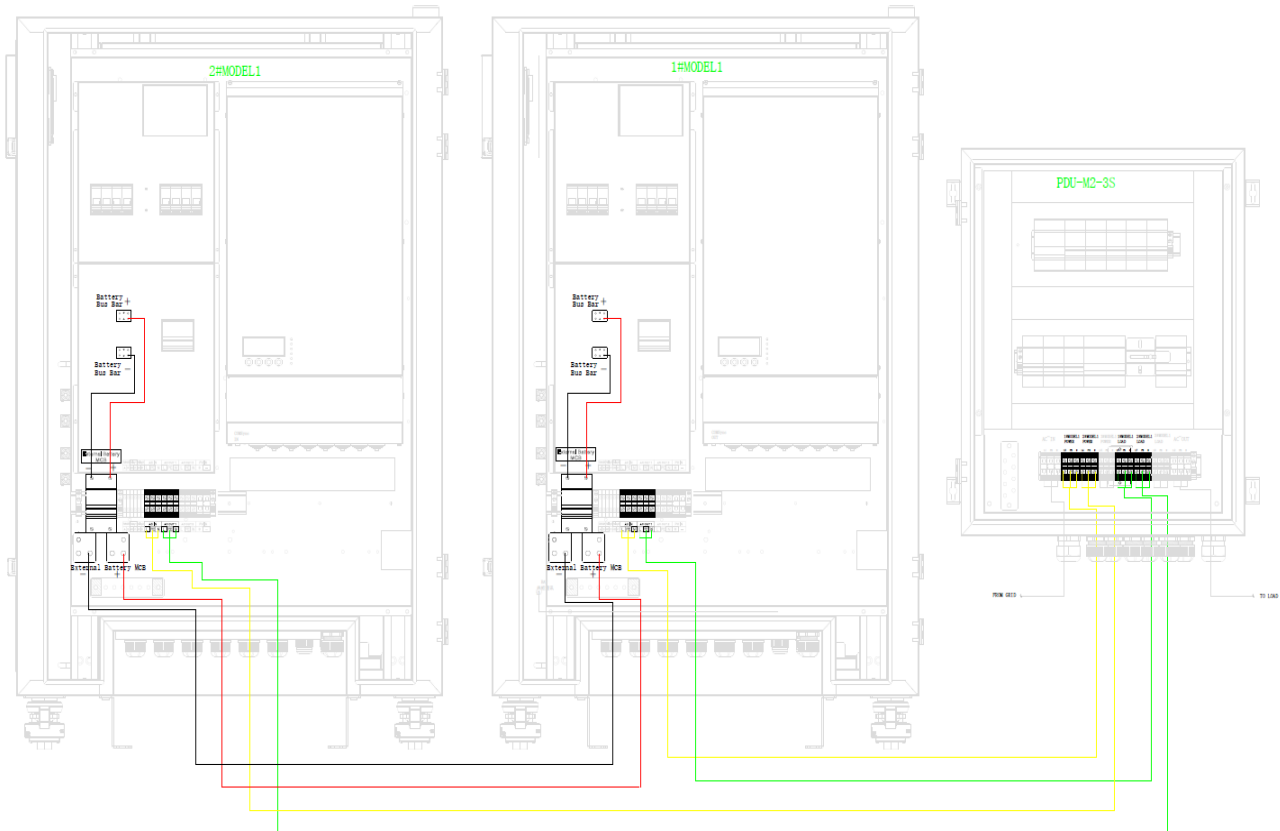

- The electrical components, installation accessories, and DC distribution cables for the parallel connection of 1#MODEL1 and 2#MODEL1 are enclosed in the KIT-M1-2P installation package.
- The AC cables connecting the input/output terminals of PDU-M2-3S AC distribution box to the AC IN and AC OUT ports of two sets of Raython Model 1 cabinets connected in parallel are to be provided by the distributors or prepared by owners.
- Please refer to information package delivered with the distribution box, the electronic files provided by the manufacturer after-sale division, or the relevant websites for the detailed electrical schematic diagram for cabinets in parallel connection.

### 3.2.2 Diagram on AC & DC power cables wiring connection for three Raython Model 1 parallel connection in single-phase.

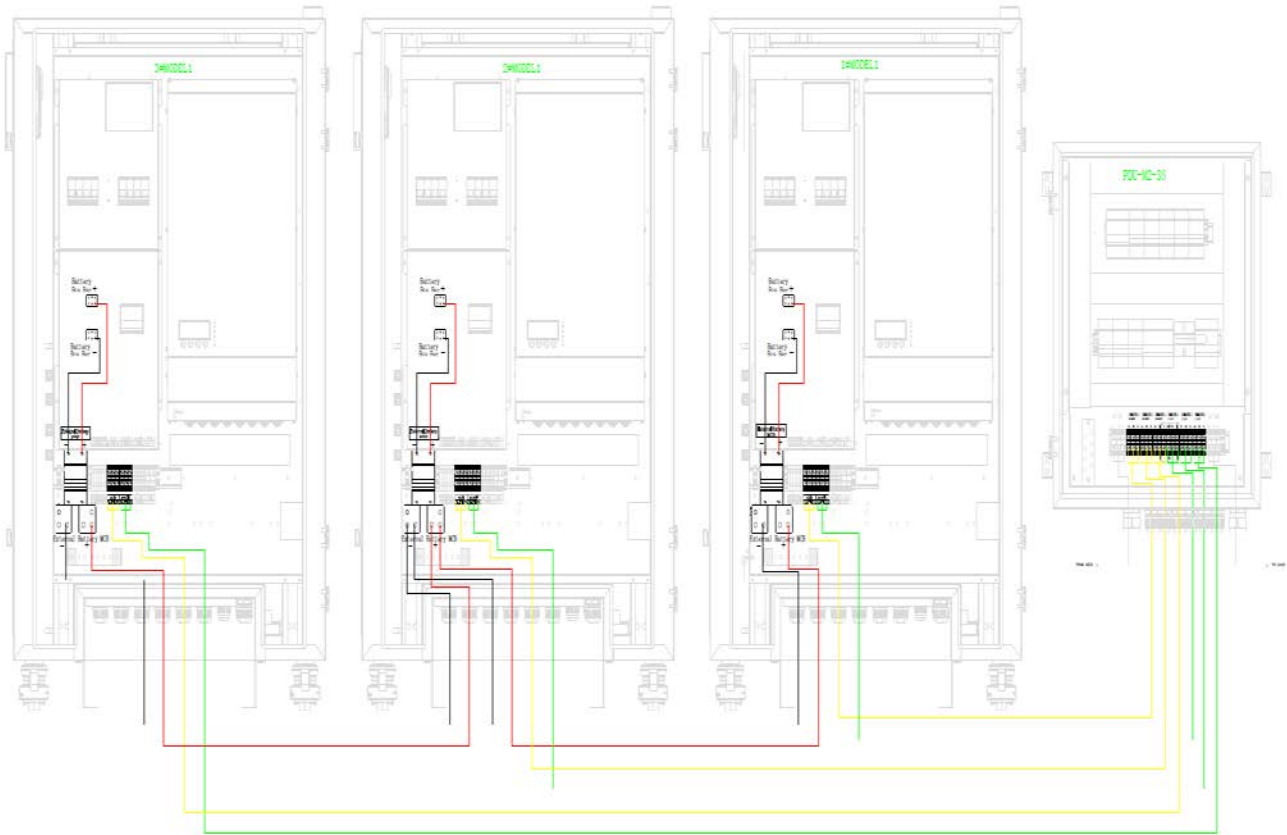

- The electrical components, installation accessories, and AC power cables for the parallel connection of 1#MODEL1, 2#MODEL1, and 3#MODEL1 are enclosed in the KIT-M1-3P installation package.
- The AC cables connecting the input/output terminals of PDU-M2-3S AC distribution box to the AC IN and AC OUT ports of three Raython Model 1 cabinets connected in parallel will be provided by distributors or prepared by owners.
- Please refer to information package delivered with the distribution box, the electronic files provided by the manufacturer after-sale division, or the relevant websites for the detailed electrical schematic diagram for cabinets in parallel connection.

### 3.2.3 Diagram on AC & DC power cables wiring connection for two Raython Model 1 parallel connection in single-phase

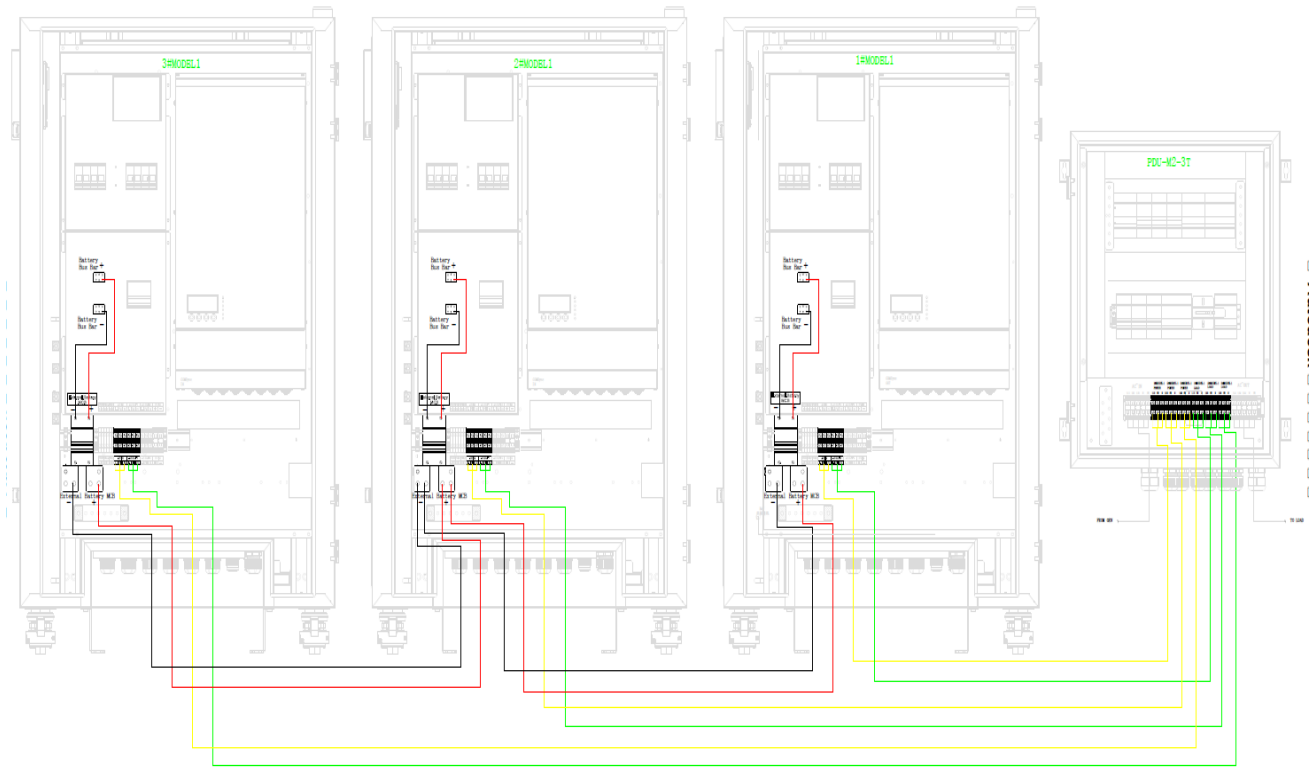

- The electrical components, installation accessories, and AC power cables for the parallel connection of 1#MODEL1, 2#MODEL1, and 3#MODEL1 are enclosed in the KIT-M1-3P installation package.
- The AC cables connecting the input/output terminals of PDU-M2-3T AC distribution box to the AC IN and AC OUT ports of three Raython Model 1 cabinets connected in parallel will be provided by distributors or prepared by owners.
- Please refer to information package delivered with the distribution box, the electronic files provided by the manufacturer after-sale division, or the relevant websites for the detailed electrical schematic diagram for cabinets in parallel connection.

**3.3** Brief intro to the connection of communication cable for Raython Model 1 cabinet parallel connection:

**3.3.1** Diagram on two Raython Model 1 parallel connection in single-phase.

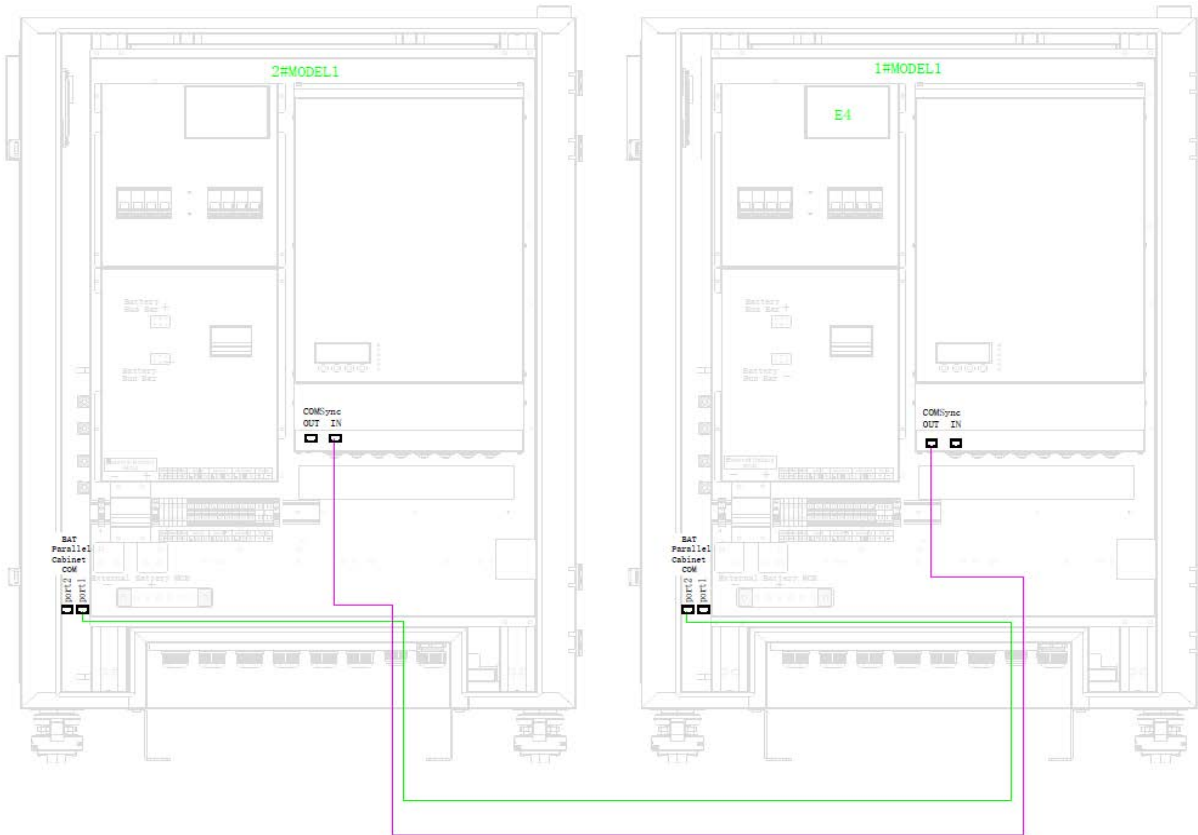

- The communication cables for the parallel connection of 1#MODEL1 and 2#MODEL1 are enclosed in the KIT-M1-2P installation package.
- Please refer to information package delivered with the distribution box, the electronic files provided by the manufacturer after-sale division, or the relevant websites for the detailed communication diagram for cabinets in parallel connection.

3.3.2 Diagram on three Raython Model 1 parallel connection in single-phase or three-phase.

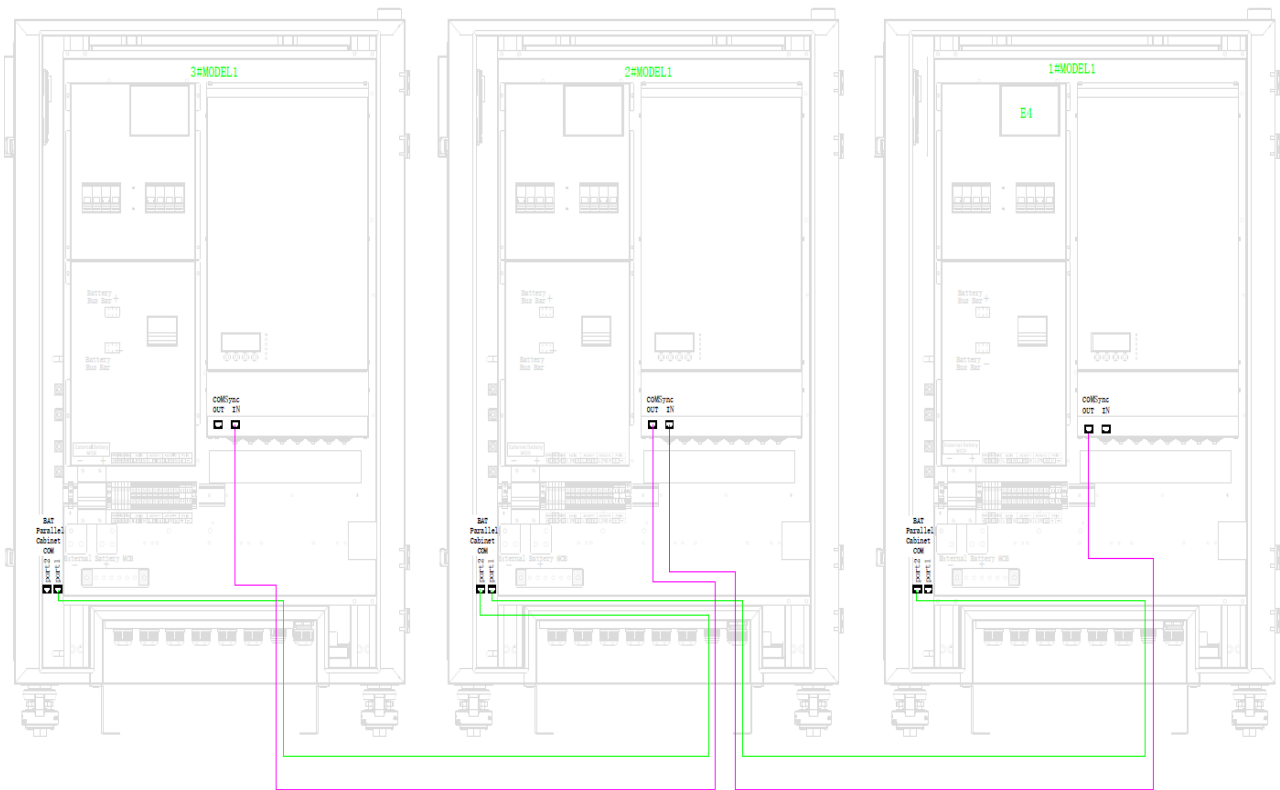

- The communication cables for the parallel connection of 1#MODEL1, 2#MODEL1, and 3#MODEL1 are enclosed in the KIT-M1-3P installation package.
- Please refer to information package delivered with the distribution box, the electronic files provided by the manufacturer after-sale division, or the relevant websites for the detailed communication diagram for cabinets in parallel connection.

**3.4 Partial layout diagram of the electrical components and connecting terminals location in the Raython Model 2 for cabinet parallel connection:**

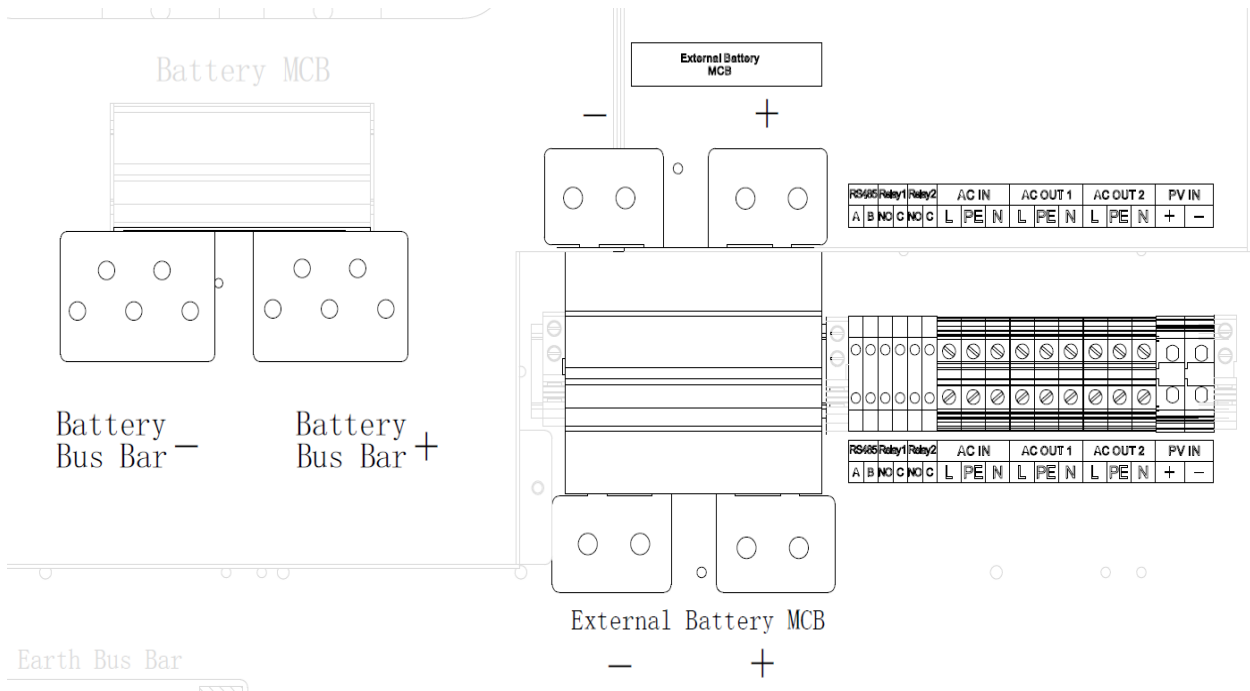

**3.5 Brief intro to the connection of power cable for Raython Model 2 cabinets parallel connection:**

**3.5.1 Diagram on AC & DC power cables wiring connection for two Raython Model 2 parallel connection in single-phase**

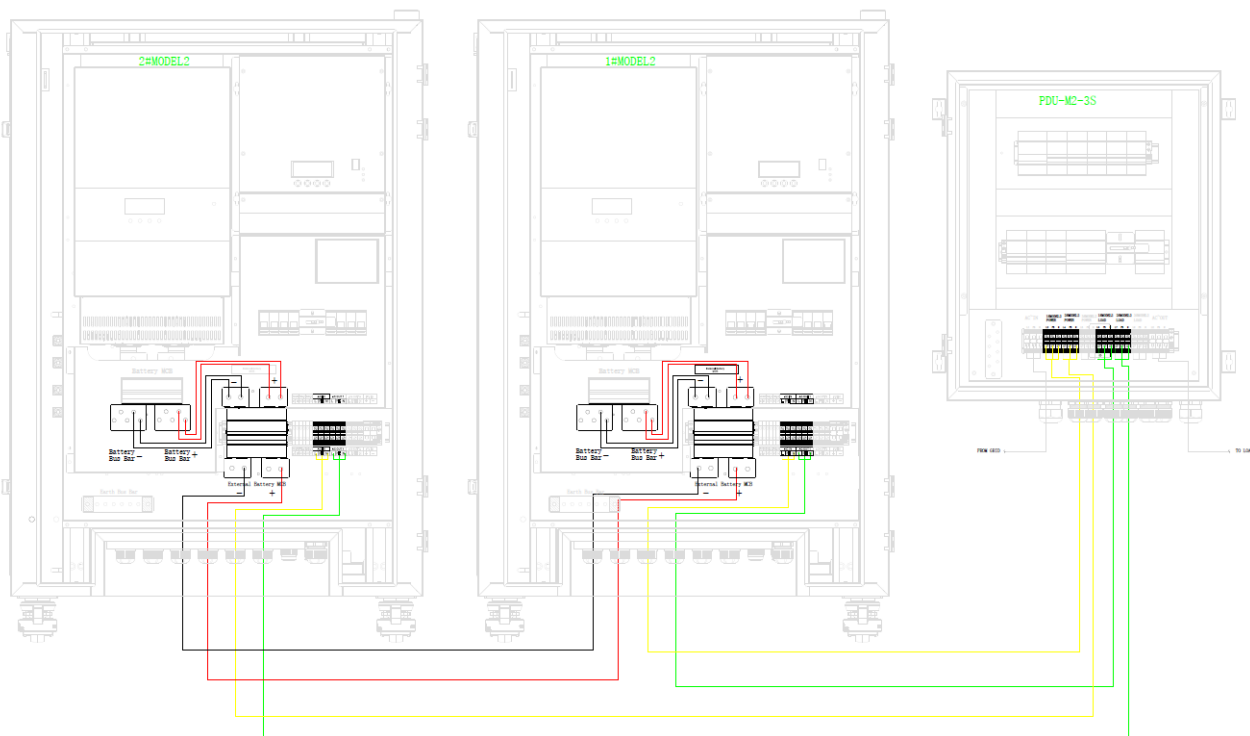

- The electrical components, installation accessories, and DC distribution cables for the parallel connection of 1#MODEL2 and 2#MODEL2, and 3#MODEL2 are enclosed in the KIT-M2-2P installation package.
- The AC cables connecting the input/output terminals of PDU-M2-3S AC distribution box to the AC IN and AC OUT ports of two Raython Model 2 cabinets connected in parallel will be provided by distributors or prepared by owners.
- Please refer to information package delivered with the distribution box, the electronic files provided by the manufacturer after-sale division, or the relevant websites for the detailed electrical schematic diagram for cabinets in parallel connection.

**3.5.2 Diagram on AC & DC power cables wiring connection for three Raython Model 2 parallel connection in single-phase**

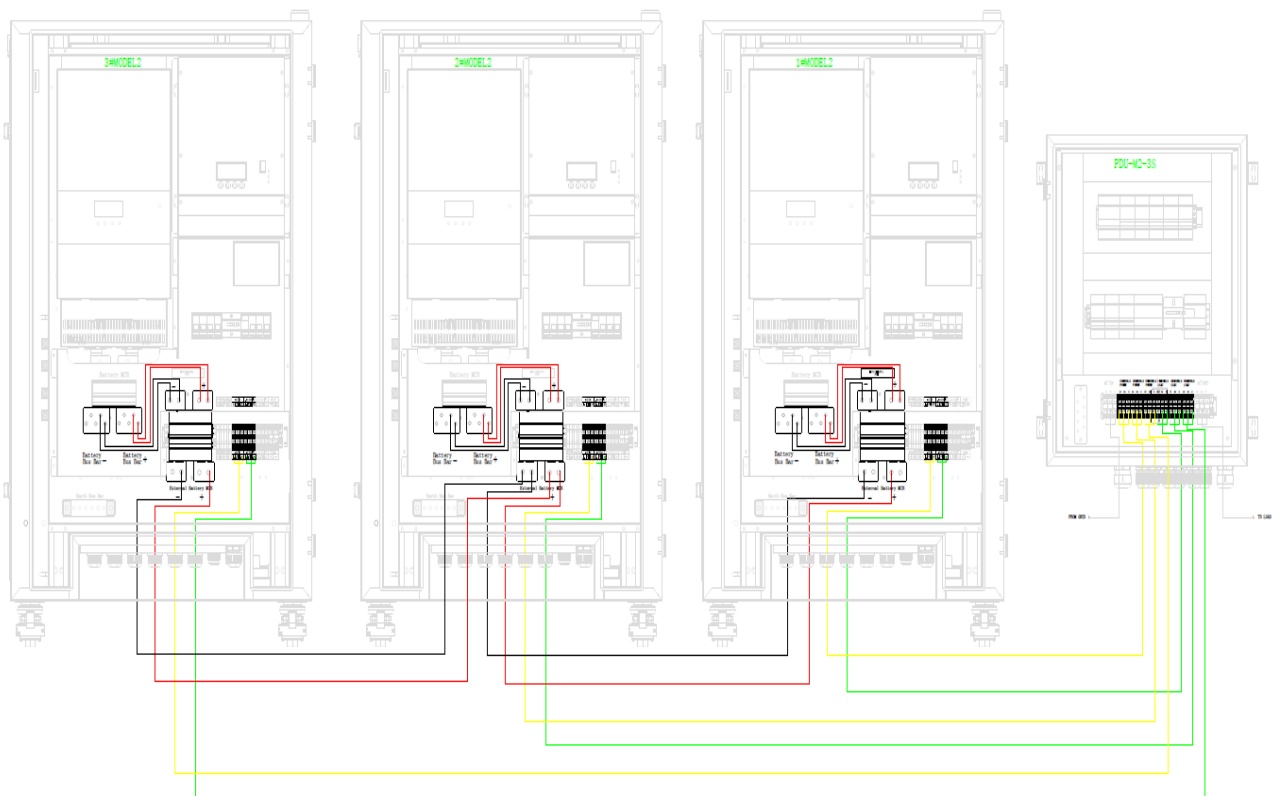

- The electrical components, installation accessories, and DC distribution cables for the parallel connection of 1#MODEL2, 2#MODEL2, and 3#MODEL2 are enclosed in the KIT-M2-3P installation package.
- The AC cables connecting the input/output terminals of PDU-M2-3S AC distribution box to the AC IN and AC OUT ports of three Raython Model 2 cabinets connected in parallel will be provided by distributors or prepared by owners.
- Please refer to information package delivered with the distribution box, the electronic files provided by the manufacturer after-sale division, or the relevant websites for the detailed electrical schematic diagram for cabinets in parallel connection.

**3.5.3** Diagram on AC & DC power cables wiring connection for three Raython Model 2 parallel connection in three-phase.

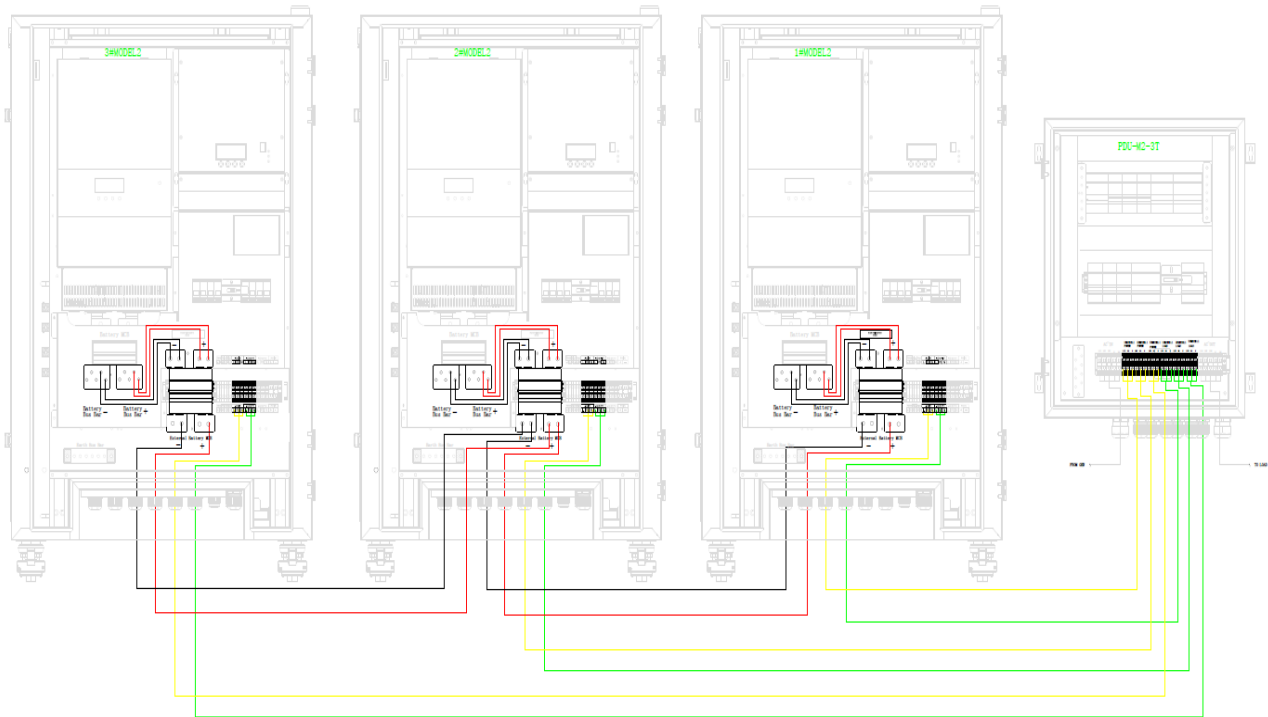

- The electrical components, installation accessories, and DC distribution cables for the parallel connection of 1#MODEL2, 2#MODEL2, and 3#MODEL2 are enclosed in the KIT-M2-3P installation package.
- The AC cables connecting the input/output terminals of PDU-M2-3T AC distribution box to the AC IN and AC OUT ports of three Raython Model 2 cabinets connected in parallel will be provided by distributors or prepared by owners.
- Please refer to information package delivered with the distribution box, the electronic files provided by the manufacturer after-sale division, or the relevant websites for the detailed electrical schematic diagram for cabinets in parallel connection.

**3.6 Brief intro to the connection of communication cable for Raython Model 2 cabinet parallel connection:**

**3.6.1 Diagram on two Raython Model 2 parallel connection in single-phase.**

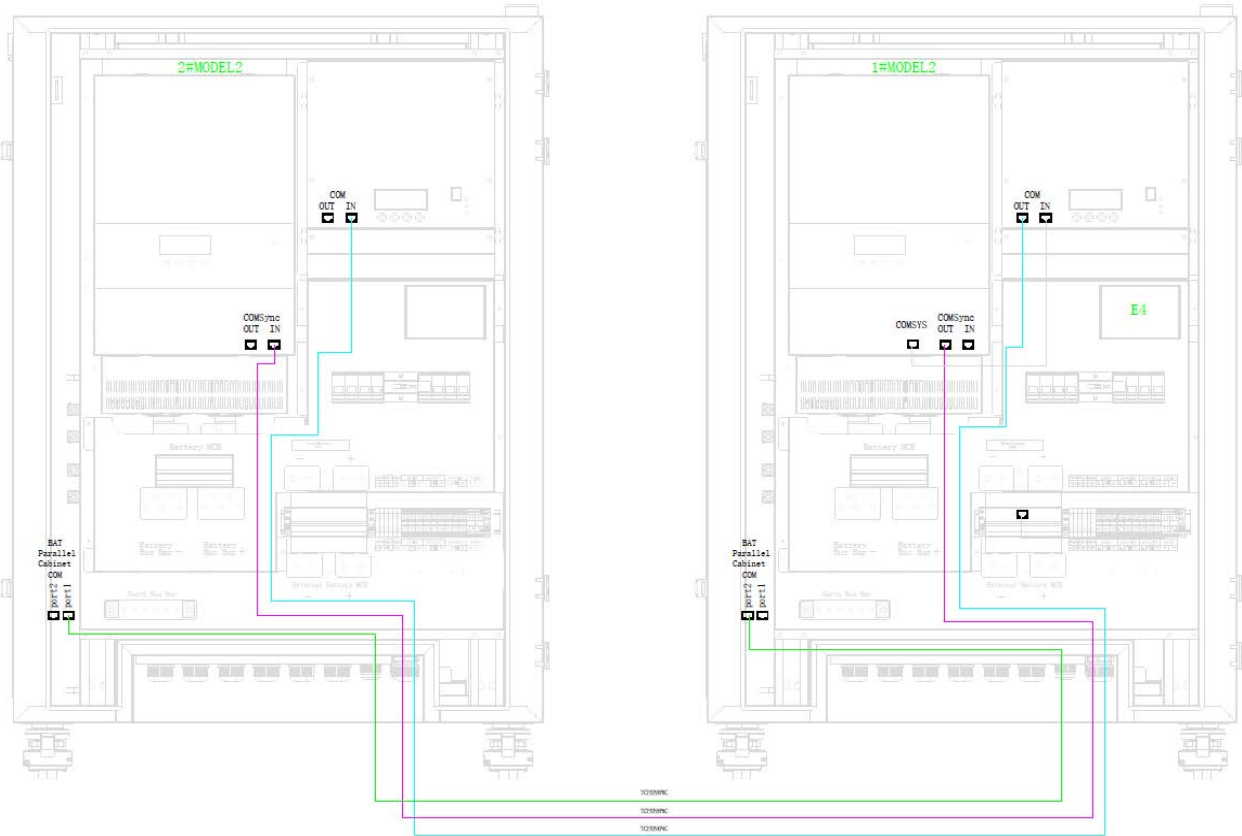

- The communication cables for the parallel connection of 1#MODEL2 and 2#MODEL2 are enclosed in the KIT-M2-2P installation package
- Please refer to information package delivered with the distribution box, the electronic files provided by the manufacturer after-sale division, or the relevant websites for the detailed communication diagram for cabinets in parallel connection.

**3.6.2 Diagram on three Raython Model 2 parallel connection in single-phase or three-phase.**

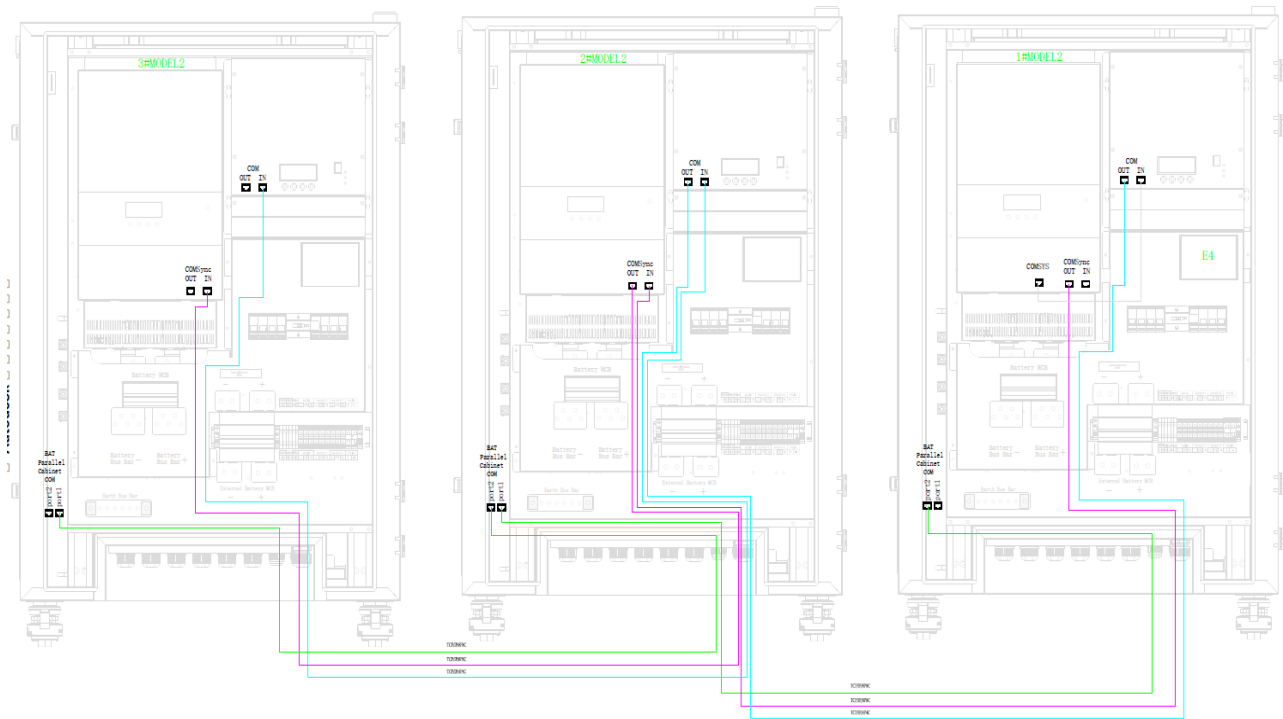

- The communication cables for the parallel connection of 1#MODEL2, 2#MODEL2, and 3#MODEL2 are enclosed in the KIT-M2-3P installation package.
- Please refer to information package delivered with the distribution box, the electronic files provided by the manufacturer after-sale division, or the relevant websites for the detailed communication diagram for cabinets in parallel connection.

**4. Description of precautions**

- When Raython Model 1&2 cabinets are connected in parallel, the number, brand, model, capacity, internal resistance, and voltage of the battery packs inside each cabinet must meet the cabinet's battery requirements to be used in parallel. (Mixed usage of old & new battery packs, battery packs with different parameters, or defective battery packs are highly prohibited.) It is strictly prohibited to use the battery packs with issues such as inconsistency in parameters, mix of new and old batteries, or defective battery packs .
- The default length of the cable for cabinets parallel connection is 3m. Installers are expected to arrange the distance between cabinets appropriately based on this.
- If the distance between cabinets has to be increased due to layout matters, it is suggested to lengthen the cable to no more than 5m. (The lengthened cable should be provided by installer. Manufacturer will not be responsible for this.)

- The self-made cables for cabinet parallel connection should be from the same batch with the same diameter and length and the same specification of copper jointing sleeve for cable crimping, in order to make cables with consistent internal resistance. The red cable should be used for the positive pole of the battery pack, while the black one for the negative pole.
- The torque of the M8 screw fixing the battery pack copper cable jointing sleeve to the copper bar of circuit breaker should be kept between 16 to 18N/m.
- The current carrying capacity of the AC power cables connecting PDU-M2-3T/3S distribution box and Raython Model 1&2 cabinets should meet with the system requirement and the cable lengths should be as consistent as possible, so as to better allocate energy for the parallel cabinets.

## 5. Parameters setting for parallel connection

5.1 Parameters setting for parallel connection of two or three Raython Model 1&2 cabinets in single-phase:

- E4 parameters setting is listed as follow:

Settings	Description
Parallel number	You should set the actual number of Model 1&2 that are connected to the system Setting method: Advanced Setting → System → Parallel → Parallel Number
Zero Export Load	Working Mode, No load is connected to the AC input, and the AC output power supply sequence is PV > battery > grid
Rated Output Voltage (V)	Select AC OUT voltage, Setting method: Advanced Setting → Inverter → Normal → Rated Output Voltage (V)
Rated Output Frequency (Hz)	Select AC OUT frequency, Setting method: Advanced Setting → Inverter → Normal → Rated Output Frequency (Hz)
Battery type	Li-Batt
Battery Ah	Set based on the battery's specification and capacity
AC in Charge	Select Enable/Disable to decide whether to allow the grid to charge the battery. Advanced Setting → Working Mode → AC in Charge
Time Zone	Set the time zone based on where the user is located
Data & Time	Set year, month, day, hour, minute

- INV parameters setting is listed as follow:

Settings	Description
Parallel_ System 1-Parallel	Select single-phase & parallel system
Parallel_ Address	Set the host cabinet Address as 1, Slave cabinet 1 Address as 2, and Slave cabinet 2 Address as 3

## 5.2 Parameters setting for parallel connection of three Raython Model 1&2 cabinets in three-phase:

- E4 parameters setting is listed as follow:

Settings	Description
Parallel number	You should set the actual number of Model 1&2 that are connected to the system Setting method: Advanced Setting → System→ Parallel→ Parallel Number.
Solar Model	Set it to DC Coupling only.
Zero Export Load	Working Mode, No load is connected to the AC input, and the AC output power supply sequence is PV > battery > grid.
Rated Output Voltage (V)	Select AC OUT voltage, Setting method: Advanced Setting → Inverter→ Normal→ Rated Output Voltage (V)
Rated Output Frequency (Hz)	Select AC OUT frequency, Setting method: Advanced Setting → Inverter→ Normal→ Rated Output Frequency (Hz)
Battery type	Li-Batt
Battery Ah	Set based on the battery's specification and capacity
AC in Charge	Select Enable/Disable to decide whether to allow the grid to charge the battery. Advanced Setting→ Working Mode→ AC in Charge.
Time Zone	Set the time zone based on where the user is located
Data & Time	Set year, month, day, hour, minute

- INV parameters setting is listed as follow:

Settings	Description
Parallel_ System 2-Three Phase	Select parallel & three-phase system
Parallel_ UVW	Set the host cabinet as 1-Phase-U (L1), Slave cabinet 1 as 2- Phase-V (L2), and Slave cabinet 2 as 3-Phase-W (L3).
Parallel_ Address	Set the Host cabinet Address as 1, Slave cabinet 1 Address as 1, and Slave cabinet 2 Address as 1.

## 5.3 Parameters setting for connecting the Solar Mate inside the Raython Model 2:

Note: Raython Model 1 MPPT setting remains the default value.

- E4 parameters setting is listed as follow:

Settings	Description
Solar Mode	Set it to DC Coupling Setting method: Advanced Setting → System→ Solar Mode→DC Coupling
INV MPPT Number	Set the quantity of Solar Mate Setting method: Advanced Setting→ Working Mode→ INV MPPT Number

- Solar Mate parameters setting is listed as follow:

Settings	Description
SYS_ Module_ Address	When setting the address for Solar Mate, if there are 3 Solar Mate connecting to the host inverter, address 1,2, and 3 should be set for these three Solar Mate respectively.

## **TBB Renewable (Xiamen) Co., Ltd.**

 TBBsupport@tbbrenewable.com

 [www.tbbrenewable.com](http://www.tbbrenewable.com)

 +86-592-5796068 /5796287

 +86-592-5796070